

**Non-Confidential Business Information
(Non-CBI)**

Certification Test Report

**Hearth and Home Technologies
Freestanding Single Burn Rate Wood Stove
Model: Aspen C3**

Prepared for: Hearth and Home Technologies, Inc.
352 Mountain House Road
Halifax, PA 17032

Prepared by: OMNI-Test Laboratories, Inc.
13327 NE Airport Way
Portland, OR 97230
(503) 643-3788

Test Period: January 15, 2019 – January 18, 2019

Report Date: March 29, 2019

Report Number: 0135WS044E

All data and information contained in this report are confidential and proprietary to Hearth and Home Technologies. Its significance is subject to the adequacy and representative character of the samples and to the comprehensiveness of the tests, examinations, or surveys made. The contents of this report cannot be copied or quoted, except in full, without specific, written authorization from Hearth and Home Technologies and OMNI-Test Laboratories, Inc. No use of the OMNI-Test Laboratories, Inc. name, logo, or registered mark (O-TL) is permitted, except as expressly authorized by OMNI-Test Laboratories, Inc. in writing.

AUTHORIZED SIGNATORIES

This report has been reviewed and approved by the following authorized signatories:

Evaluator:



Bruce Davis,
Technician

QA Review:

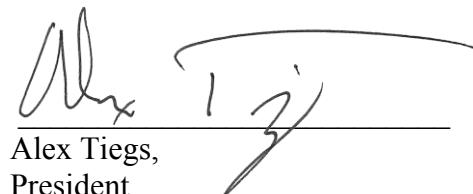

Alex Tiegs,
President

TABLE OF CONTENTS

	PREFACE.....	(3 pages)
1.	SAMPLING PROCEDURES AND TEST RESULTS.....	4
	Introduction.....	5
	Individual Run Summaries	6
	Table 1 - Particulate Emissions Results.....	7
	Table 2 - Particulate Emissions Results (First Hour).....	7
	Table 3 – B415.1 Efficiency and CO Emissions	7
	Table 4 - Test Facility Conditions	8
	Table 5 - Fuel Measurements and Crib Descriptions - Pretest	8
	Table 6 - Fuel Measurements and Crib Descriptions - Test	8
	Table 7 - Dilution Tunnel Gas Measurements and Sampling Data	9
	Table 8 – Average Temperature Data.....	9
	Table 9 - Pretest Configurations	9
	Table 10 - Test Configurations	10
2.	PHOTOGRAPHS/APPLIANCE DESCRIPTION/DRAWINGS.....	11
	Fuel Photographs	13
	Appliance Description	15
3.	TEST DATA BY RUN.....	16
	Run 1	18
	Run 2	30
	Run 3	38
	Run 4.....	49
4.	QUALITY ASSURANCE/QUALITY CONTROL	61
	Sample Analysis.....	63
	Calibrations – EPA Method 28R, ASTM E2515, ASTM E2780	71
	Example Calculations	90
5.	LABELING & OWNER’S MANUAL.....	106

Section 1

Sampling Procedures and Test Results

INTRODUCTION

Hearth and Home Technologies retained *OMNI* to perform U.S. Environmental Protection Agency (EPA) certification testing on the Aspen C3 wood stove. The Aspen C3 wood stove is a radiant freestanding-type non-catalytic single burn rate room heater. The firebox is constructed of cast iron. Usable firebox volume was measured to be 1.25 cubic feet and the stove is vented through a six-inch flue collar located at the rear of the stove top.

The testing was performed at OMNI-Test Laboratories located in Portland Oregon. The altitude of the laboratory is 30 feet above sea level. The unit was received in good condition and logged in on January 15, 2019, then assigned and labeled with *OMNI* ID #2339. *OMNI* representative Bruce Davis conducted the certification testing and completed all testing by January 18, 2019.

This report is organized in accordance with the EPA-recommended outline and is summarized in the Table of Contents immediately preceding this section. The results in this report are limited to the item submitted.

SAMPLING PROCEDURE

The Aspen C3 wood stove was tested in accordance with the U.S. EPA 40 CFR Part 60, Subpart AAA – Standards of Performance for New Residential Wood Heaters using EPA Method 28R, ASTM E2515 and ASTM E2780. Particulate emissions were measured using sampling trains consisting of two filters (front and back).

The model Aspen C3 was tested for thermal efficiency and carbon monoxide (CO) emissions in accordance with CSA B415.1-10.

SUMMARY OF RESULTS

The average emissions of the two test runs included in the results indicate a particulate emission rate of 1.99 grams per hour. A total of four tests were conducted, run one was omitted based on only using two thirds of tests in a category. Run two was omitted due to an issue that occurred during fuel loading. A fuel piece contacted the baffle and caused a component of the baffle system to move out of place. Misplacement of the baffle component caused a restriction in the flue gas passage and invalidated the test. An average of tests 3 and 4 are within the emission limit of 2.0 g/hr. for affected facilities using crib fuel manufactured on or after May 15, 2020.

The proportionality results for all 4 test runs were acceptable. Quality check results for each test run are presented in Section 4 of this report.

INDIVIDUAL RUN SUMMARIES – Certification Testing

- Run 1 -** Operating procedures provided by the manufacture were followed to generate a 1.46 kg/h burn rate. There are no user controls on the appliance that can be used to alter burn rate. Emissions results were higher than expected and the test was omitted on a two for one basis.
- Run 2 -** Operating procedures provided by the manufacture were followed to start an emissions test, during fueling the baffle system was dislodged. This test was stopped due to equipment failure.
- Run 3 -** Operating procedures provided by the manufacture were followed to generate a 1.24 kg/h burn rate. There are no user controls on the appliance that can be used to alter burn rate. No sampling anomalies occurred during the test, results were used in calculating final emissions rate.
- Run 4 -** Operating procedures provided by the manufacture were followed to generate a 1.24 kg/h burn rate. There are no user controls on the appliance that can be used to alter burn rate. No sampling anomalies occurred during the test, results were used in calculating final emissions rate.

Table 1 – Particulate Emissions

Run	Burn Rate (kg/hr dry)	ASTM E2515 Emissions (g/hr)
1	1.46	3.00
2	1.26	N/A
3	1.24	2.22
4	1.25	1.76

Average emissions of 2 test runs: $(2.22 + 1.76) / 2 = 1.99$ grams per hour.

Note: Run number one was omitted on a two for one basis, run two was omitted due to equipment failure.

Table 2 – Particulate Emissions (First Hour)

Run	ASTM E2515 Emissions – First Hour (g/hr)
1	5.40
2	N/A
3	*N/A
4	2.21

*Filter change at one hour was inadvertently overlooked.

Table 3 – B415.1 Efficiency and CO Emissions

Run	Heat Output (BTU/hr)	HHV Efficiency (%)	LHV Efficiency (%)	CO Emissions (g/MJ Output)	CO Emissions (g/kg Dry Fuel)	CO Emissions (g/min)
1	20,086	74.3	80.4	5.51	81.04	1.944
3	17,439	75.0	81.2	4.81	71.54	1.475
4	17,550	75.4	81.6	4.58	68.44	1.413

Average CO emissions in grams per minute: **1.61 g/min.**
 Average HHV efficiency tests 3 and 4: **75.2%.**

Note: Run number one was omitted on a two for one basis.

Table 4 – Test Facility Conditions

Run	Room Temperature (°F)		Barometric Pressure (Hg)		Air Velocity (ft/min)	
	Before	After	Before	After	Before	After
1	66	68	29.91	29.84	<50	<50
3	68	66	29.56	29.65	<50	<50
4	69	70	30.15	30.03	<50	<50

Table 5 – Fuel Measurement and Crib Description Summary – PRETEST

Run	Pretest Fuel Weight (Starting weight in lbs)	Pretest Moisture (Dry basis - %)	Coal Bed Weight (lbs)
1	9.5	19.97	2.0
3	9.2	22.63	1.9
4	9.2	20.39	2.0

Table 6 – Fuel Measurement and Crib Description Summary – TEST

Run	Test Fuel Wet Basis (lbs)	Firebox Volume (ft ³)	Fuel Loading Density Wet Basis (lbs/ft ³)	Test Fuel Dry Basis (lbs)	Piece Length (in)	2x4s Used	4x4s Used
1	9.2	1.25	7.36	7.8	16.0	4	0
3	8.8	1.25	7.04	7.3	16.0	4	0
4	8.8	1.25	7.04	7.4	16.0	4	0

Table 7 – Dilution Tunnel Gas Measurements and Sampling Data Summary

Run	Length of Test (min)	Average Dilution Tunnel Gas Measurements		
		Velocity (ft/sec)	Flow Rate (dscf/min)	Temperature (°F)
1	145	14.05	156.3	87
3	160	14.24	158.0	84
4	160	14.16	158.8	86

Table 8 - Average Temperature Data

Run	Beginning Surface Temperature Average ^a	Ending Surface Temperature Average ^a	Surface Delta T ^b
1	353	305	48
3	365	287	78
4	358	292	66

a. All temperatures are in degrees F.
 b. Represents the difference between beginning and ending average surface temperatures.

Table 9 – Pretest Configuration

Run	Combustion Air	Fuel Added	Fuel Removed	Time (min)
1	N/A	14.1	0	87
3	N/A	10.3	0	83
4	N/A	10.1	0	66

Table 10 – Test Configurations

Run	Five-Minute Startup Procedures	Combustion Air
1	<u>Fuel Loading</u> : Fuel loaded by 50 seconds <u>Door</u> : Closed by 55 seconds <u>Bypass</u> : N/A <u>Primary Air</u> : No user adjustment <u>Secondary</u> : No user adjustment <u>Fan</u> : N/A	No user adjustment
3	<u>Fuel Loading</u> : Fuel loaded by 55 seconds <u>Door</u> : Closed by 55 seconds <u>Bypass</u> : N/A <u>Primary Air</u> : No user adjustment <u>Secondary</u> : No user adjustment <u>Fan</u> : N/A	No user adjustment
4	<u>Fuel Loading</u> : Fuel loaded by 50 seconds <u>Door</u> : Closed by 55 seconds <u>Bypass</u> : N/A <u>Primary Air</u> : No user adjustment <u>Secondary</u> : No user adjustment <u>Fan</u> : N/A	No user adjustment

Section 2

Photographs/Appliance Description/Drawings

Hearth and Home Technologies Aspen C3



Hearth and Home Technologies Aspen C3

Run 1 – Fuel



Run 1 – Newly Loaded Stove



Run 2 – Fuel



Run 2 – Newly Loaded Stove



Hearth and Home Technologies Aspen C3

Run 3 – Fuel



Run 3 – Newly Loaded Stove



Run 4 – Fuel



Run 4 – Newly Loaded Stove

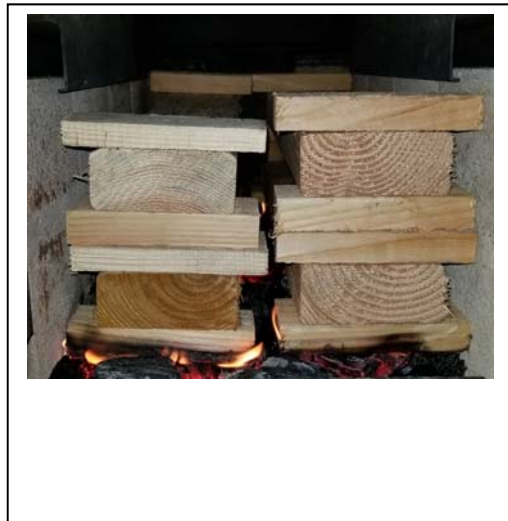

WOOD HEATER DESCRIPTION

Appliance Manufacturer: Hearth and Home Technologies

Wood Stove Model: Aspen C3

Type: Radiant freestanding

WOOD HEATER INFORMATION

Materials of Construction: The unit is constructed primarily of cast iron. The firebox is lined with refractory brick that measures 4.5" x 9" x 1.25". The feed door has an 8.28" x 9.16" glass panel and 3/16" gasket.

Air Introduction System: Combustion air enters the appliance through a round opening in the firebox back. Air is channeled to secondary air ports located at the rear of the baffle system, and to air ports directed at the glass for an air wash system.

Combustion Control Mechanisms: Primary air is controlled by a Bi-metallic spring thermostat located at the rear of the stove inside the outside air collar. As the appliance heats it causes the spring to expand and lower a plate over the combustion air opening. The spring assembly is not accessible to tampering, no user controls are offered that could alter the burn rate.

Combustor: N/A

Internal Baffles: A C-Cast baffle is located at the top of the fire chamber, it is located so flames must travel to the front of the fire chamber around the front edge of the baffle.

Other Features: N/A

Flue Outlet: The 6" diameter flue outlet is located in the top rear of the unit.

WOOD HEATER OPERATING INSTRUCTIONS

Specific Written Instructions: See Section 5 of this report. All markings and instruction materials were reviewed for content prior to printing.

Section 3

Test Data by Run

2020 Aspen C3 Operation

The following operating procedures are supplied as guidance for certification runs on the Aspen C3 fixed air setting woodstove. Procedures outlined have resulted in coalbeds and stove temperatures resulting in compliant tests.

The Aspen C3 is a thermostatically controlled fixed air setting stove (“single burn rate”) and therefore only one testing scheme is required.

Startup:

2-3 lbs of kindling with 2 pcs of 2x4x8” on top.

Light the kindling and after 2 or 3 minutes with kindling fully ignited, close the door.

Preburn:

12 pcs of 2x4x8” D.fir

Add wood once kindling has burned down to about 2 lbs. Stack pieces with about 1” space between and on edge. Burn with door cracked open until 9.5 lbs, then close the door. No need to stir the wood during the preburn.

Test Load:

At the coalbed weight, break up and level coals immediately prior to adding test fuel. Add test fuel and close the door immediately.

Stove average temperatures of between 360 and 400 degrees have been found to work for stove delta T requirements.

Test load: 4pcs. @ 16” 19-21% DB -AK

Run 1

Wood Heater Test Results - ASTM E2780 / ASTM E2515

Manufacturer: Hearth & Home
 Model: Aspen C3
 Project No.: 0135WS044E
 Tracking No.: 2339
 Run: 1
 Test Date: 01/15/19

Burn Rate	1.46 kg/hr dry
Average Tunnel Temperature	87 degrees Fahrenheit
Average Gas Velocity in Dilution Tunnel - vs	14.05 feet/second
Average Gas Flow Rate in Dilution Tunnel - Qsd	9380.0 dscf/hour
Average Delta p	0.053 inches H2O
Total Time of Test	145 minutes

	AMBIENT	SAMPLE TRAIN 1	SAMPLE TRAIN 2	FIRST HOUR FILTER (TRAIN 1)
Total Sample Volume - Vm	0.000 cubic feet	23.539 cubic feet	23.666 cubic feet	9.678 cubic feet
Average Gas Meter Temperature	68 degrees Fahrenheit	78 degrees Fahrenheit	79 degrees Fahrenheit	78 degrees Fahrenheit
Total Sample Volume (Standard Conditions) - Vmstd	0.000 dscf	22.827 dscf	22.849 dscf	9.385 dscf
Total Particulates - m _p	0 mg	7 mg	7.6 mg	5.4 mg
Particulate Concentration (dry-standard) - C _p /C _s	0.000000 grams/dscf	0.00031 grams/dscf	0.00033 grams/dscf	0.00058 grams/dscf
Total Particulate Emissions - E _T	0.00 grams	6.95 grams	7.54 grams	5.40 grams
Particulate Emission Rate	0.00 grams/hour	2.88 grams/hour	3.12 grams/hour	5.40 grams/hour
Emissions Factor		1.97 g/kg	2.14 g/kg	1.90 g/kg
Difference from Average Total Particulate Emissions		0.29 grams	0.29 grams	

Dual Train Comparison Results Are Acceptable

FINAL AVERAGE RESULTS	
Complete Test Run	
Total Particulate Emissions - E _T	7.25 grams
Particulate Emission Rate	3.00 grams/hour
Emissions Factor	2.05 grams/kg
First Hour Emissions	
Total Particulate Emissions - E _T	5.40 grams
Particulate Emission Rate	5.40 grams/hour
Emissions Factor	1.90 grams/kg

QUALITY CHECKS	
Filter Temps < 90 °F	OK
Filter Face Velocity (47 mm)	OK
Dryer Exit Temp < 80F	OK
Leakage Rate	OK
Ambient Temp (55-90°F)	OK
Negative Probe Weight Eval.	OK
Pro-Rate Variation	OK
Stove Surface ΔT	OK

Technician Signature:

Wood Heater Preburn Data - ASTM E2780

Run: 1
 Manufacturer: Hearth & Home
 Model: Aspen C3
 Tracking No.: 2339
 Project No.: 0135WS044E
 Test Date: 43480
 Beginning Clock Time: 11:04

Coal Bed
 Range **1.8** **2.3**
 (lb): (min) (max)

Technician Signature: 

Elapsed Time (min)	Scale (lb)	Stack Draft (in H ₂ O)	Temperatures (°F)							Stack	Ambient
			FB Top	FB Bottom	FB Back	FB Left	FB Right	Avg. Firebox Surface			
0	9.5	-0.075	724	97	113	265	290	297.8	597	66	
1	9.3	-0.075	729	98	113	270	295	301	562	65	
2	9.2	-0.075	730	99	114	275	300	303.6	554	66	
3	9	-0.075	734	101	114	281	304	306.8	551	66	
4	8.9	-0.074	740	102	115	286	309	310.4	555	66	
5	8.7	-0.075	747	104	116	291	313	314.2	556	66	
6	8.5	-0.073	755	105	116	296	318	318	552	65	
7	8.4	-0.074	761	107	117	301	322	321.6	550	65	
8	8.2	-0.074	767	108	118	306	327	325.2	551	66	
9	8.1	-0.072	775	110	120	312	332	329.8	541	66	
10	8	-0.071	776	112	121	317	336	332.4	525	66	
11	7.8	-0.07	776	114	122	322	341	335	508	66	
12	7.6	-0.072	777	116	123	326	345	337.4	515	66	
13	7.5	-0.071	791	118	124	331	349	342.6	529	66	
14	7.4	-0.071	800	120	125	335	353	346.6	534	66	
15	7.2	-0.071	801	121	126	339	358	349	526	66	
16	7.1	-0.072	802	123	128	343	362	351.6	521	66	
17	7	-0.071	805	124	130	347	365	354.2	524	67	
18	6.8	-0.069	805	126	132	351	369	356.6	518	67	
19	6.7	-0.068	797	127	134	354	373	357	503	67	
20	6.6	-0.067	782	129	136	357	376	356	481	67	
21	6.4	-0.067	765	130	138	361	379	354.6	470	67	
22	6.3	-0.066	753	131	141	363	383	354.2	460	67	
23	6.2	-0.065	739	133	143	366	385	353.2	451	66	
24	6.2	-0.064	727	134	145	369	388	352.6	449	67	
25	6	-0.064	715	135	148	372	390	352	439	67	
26	5.9	-0.064	705	137	150	374	392	351.6	436	67	
27	5.8	-0.063	701	138	151	377	395	352.4	438	66	
28	5.7	-0.063	699	139	153	379	397	353.4	437	67	
29	5.7	-0.062	698	140	155	382	399	354.8	432	67	
30	5.5	-0.06	689	141	157	384	402	354.6	425	66	
31	5.5	-0.061	680	141	158	386	403	353.6	417	66	
32	5.4	-0.058	667	143	160	388	406	352.8	405	67	
33	5.3	-0.058	656	144	162	391	407	352	392	68	
34	5.2	-0.057	645	145	163	393	408	350.8	387	67	
35	5.2	-0.056	636	146	164	394	409	349.8	378	67	
36	5.1	-0.055	625	147	165	395	410	348.4	375	67	
37	5	-0.056	620	148	166	397	411	348.4	377	67	
38	4.9	-0.056	616	148	167	398	413	348.4	379	67	
39	4.9	-0.057	612	149	168	399	413	348.2	377	67	
40	4.8	-0.055	611	151	169	400	414	349	378	66	
41	4.7	-0.056	611	152	171	401	415	350	381	66	
42	4.6	-0.056	611	152	172	402	416	350.6	382	66	
43	4.6	-0.055	610	153	173	403	416	351	383	66	
44	4.5	-0.056	609	154	175	404	417	351.8	381	66	
45	4.4	-0.056	609	155	176	404	418	352.4	380	66	
46	4.3	-0.056	609	155	178	405	419	353.2	381	66	
47	4.3	-0.056	609	157	180	406	419	354.2	383	66	
48	4.2	-0.054	607	158	181	406	420	354.4	380	66	
49	4.1	-0.055	604	159	183	407	421	354.8	376	66	
50	4	-0.054	601	160	185	408	421	355	370	67	
51	4	-0.054	598	161	186	408	423	355.2	364	67	
52	3.9	-0.054	595	162	188	409	423	355.4	368	66	
53	3.8	-0.054	592	162	190	410	424	355.6	365	66	

Wood Heater Preburn Data - ASTM E2780

Run: **1**

Manufacturer: Hearth & Home
 Model: Aspen C3
 Tracking No.: 2339
 Project No.: 0135WS044E
 Test Date: 43480
 Beginning Clock Time: 11:04

Coal Bed		
Range	1.8	2.3
(lb):	(min)	(max)

Technician Signature: _____

Elapsed Time (min)	Scale (lb)	Stack Draft (in H ₂ O)	Temperatures (°F)							Stack	Ambient
			FB Top	FB Bottom	FB Back	FB Left	FB Right	Avg. Firebox Surface			
54	3.8	-0.054	590	164	191	410	425	356	365	67	
55	3.7	-0.054	589	165	193	411	425	356.6	366	66	
56	3.6	-0.054	587	167	194	411	427	357.2	362	67	
57	3.6	-0.053	586	168	196	412	427	357.8	364	67	
58	3.5	-0.053	584	169	198	412	428	358.2	361	66	
59	3.4	-0.052	583	170	199	413	429	358.8	362	66	
60	3.3	-0.053	580	171	201	413	429	358.8	359	66	
61	3.3	-0.052	578	172	203	413	430	359.2	357	66	
62	3.2	-0.052	575	173	205	414	431	359.6	357	66	
63	3.2	-0.052	573	174	207	414	431	359.8	353	66	
64	3.1	-0.051	571	175	209	414	432	360.2	350	66	
65	3	-0.05	568	176	211	415	432	360.4	345	67	
66	3	-0.051	564	178	213	415	432	360.4	342	66	
67	2.9	-0.051	561	179	215	415	433	360.6	339	67	
68	2.9	-0.05	558	180	217	415	433	360.6	338	67	
69	2.8	-0.049	554	181	219	415	434	360.6	336	66	
70	2.7	-0.05	549	182	221	415	434	360.2	330	66	
71	2.7	-0.049	547	183	223	415	434	360.4	327	66	
72	2.6	-0.048	541	184	225	415	435	360	324	66	
73	2.6	-0.049	539	185	226	415	435	360	323	65	
74	2.5	-0.047	536	186	228	415	435	360	323	66	
75	2.5	-0.048	534	187	229	415	435	360	321	66	
76	2.4	-0.048	531	188	230	414	434	359.4	318	66	
77	2.4	-0.047	527	190	231	414	434	359.2	313	66	
78	2.3	-0.048	524	189	233	414	434	358.8	311	66	
79	2.3	-0.045	520	191	235	414	434	358.8	307	66	
80	2.3	-0.046	514	191	236	413	433	357.4	305	66	
81	2.2	-0.045	511	193	237	413	432	357.2	303	67	
82	2.2	-0.043	507	195	239	413	431	357	301	67	
83	2.1	-0.043	502	195	240	412	431	356	298	66	
84	2.1	-0.044	498	196	241	412	430	355.4	295	66	
85	2.1	-0.044	495	198	242	412	429	355.2	292	66	
86	2	-0.043	492	198	243	411	428	354.4	289	66	
87	2	-0.042	489	199	243	411	427	353.8	287	66	

Wood Heater Test Fuel Data - ASTM E2780

Manufacturer: **Hearth & Home**
 Model: **Aspen C3**
 Tracking No.: **2339**
 Project No.: **0135WS044E**
 Test Date: **1/15/2019**
 Run No.: **1**

Firebox Volume (ft ³):	1.25
Fuel Piece Length (in):	16
2x4 Crib Weight (lb):	9.2
4x4 Crib Weight (lb):	

Total Fuel Weight (Dry Basis, lb):	7.8	
Fuel Density (lb/ft ³ , Dry Basis):	30.86	OK
Loading Density (lb/ft ³ , Wet Basis):	7.36	OK
2x4 Percentage:	N/A	N/A

Coal Bed Range (20-25%): **1.84 - 2.3**

Test Fuel Piece	Weight (lb)	Size	Readings (Dry Basis %)			Dry Weight (lb)
1	1.8	2"x 4"	19.8	18.9	19.1	1.51
2	1.8	2"x 4"	19.4	19.5	20.0	1.50
3	1.7	2"x 4"	20.0	20.8	21.4	1.41
4	1.9	2"x 4"	19.8	20.0	21.4	1.58

Spacer Readings (Dry Basis %)			
14.7	10.0		
9.2	13.2		
10.0	15.1		
13.6			
12.0			
14.4			
9.0			
9.2			
10.6			
9.8			
15.3			
12.4			
15.1			

Technician Signature: 

Wood Heater Lab Data - ASTM E2780 / ASTM E2515

Manufacturer: Hearth & Home Equipment Numbers: 131, 343
 Model: Aspen C3 Tracking
 No.: 2339
 Project No.: 0135WS044E
 Run #: 1
 Date: 1/15/19

TRAIN 1 (First Hour emissions)

Sample Component	Reagent	Filter, Probe or Dish #	Weights		
			Final, mg	Tare, mg	Particulate, mg
B. Front filter catch	Filter	D644	126.3	120.9	5.4
C. Rear filter catch	Filter				0.0
D. Probe catch*	Probe				0.0
E. Filter seals catch*	Seals				0.0

Sub-Total Total Particulate, mg: **5.4**

TRAIN 1 (Post First Hour Change-out)

Sample Component	Reagent	Filter, Probe or Dish #	Weights		
			Final, mg	Tare, mg	Particulate, mg
B. Front filter catch	Filter	D645	121.6	120.8	0.8
C. Rear filter catch	Filter	D646	121.6	121.5	0.1
D. Probe catch*	Probe	17	114561.9	114561.2	0.7
E. Filter seals catch*	Seals	R711	4104.9	4104.9	0.0

Sub-Total Total Particulate, mg: **1.6**

Train 1 Aggregate Total Particulate, mg: **7.0**

TRAIN 2

Sample Component	Reagent	Filter, Probe or Dish #	Weights		
			Final, mg	Tare, mg	Particulate, mg
A. Front filter catch	Filter	D647	127.1	121.1	6.0
B. Rear filter catch	Filter	D648	120.7	120.6	0.1
C. Probe catch*	Probe	18	114402.6	114401.5	1.1
D. Filter seals catch*	Seals	R712	3414.0	3413.6	0.4

Total Particulate, mg: **7.6**

AMBIENT

Sample Component	Reagent	Filter # or Probe #	Weights		
			Final, mg	Tare, mg	Particulate, mg
A. Front filter catch*	Filter				0.0

Total Particulate, mg: **0.0**

*Particulate catch that results in a negative number, is assumed to be zero for probes and seals, negative numbers for filters are assumed to be part of the seal weight.

Component	Equations:
A. Front filter catch	Final (mg) - Tare (mg) = Particulate, mg
B. Rear filter catch	Final (mg) - Tare (mg) = Particulate, mg
C. Probe catch	Final (mg) - Tare (mg) = Particulate, mg

Technician Signature: 

Manufacturer: Hearth & Home
Model: Aspen C3
Date: 01/15/19
Run: 1
Control #: 0135WS044E
Test Duration: 145
Output Category: 3

Technicians: *B. K.*

Test Results in Accordance with CSA B415.1-09

	HHV Basis	LHV Basis
Overall Efficiency	74.3%	80.4%
Combustion Efficiency	94.1%	94.1%
Heat Transfer Efficiency	79%	85.4%

Output Rate (kJ/h)	21,174	20,086	(Btu/h)
Burn Rate (kg/h)	1.44	3.17	(lb/h)
Input (kJ/h)	28,513	27,048	(Btu/h)

Test Load Weight (dry kg)	3.48	7.67	dry lb
MC wet (%)	16.67		
MC dry (%)	20.00		
Particulate (g)	7.25		
CO (g)	282		
Test Duration (h)	2.42		

Emissions	Particulate	CO
g/MJ Output	0.14	5.51
g/kg Dry Fuel	2.08	81.04
g/h	3.00	116.64
lb/MM Btu Output	0.33	12.80

Air/Fuel Ratio (A/F)	10.44
-----------------------------	-------

VERSION: 2.2 12/14/2009

VERSION: 2.2

12/14/2009

Manufacturer: Hearth & Home

Appliance Type: Non-Cat

Model: Aspen C3

Date: 1/15/2019

Temp. Units F (F or C)

Run: 1

Weight Units lb (kg or lb)

Control #: 0135WS044E

Test Duration: 145

Output Category: 3

Fuel Data

D. Fir

Wood Moisture (% wet): 16.67
 Load Weight (lb wet): 9.20
 Burn Rate (dry kg/h): 1.44
 Total Particulate Emissions: 7.25 g

HHV 19,810 kj/kg
 %C 48.73
 %H 6.97
 %O 43.8
 %ASH 0.5

Averages 1.08 10.58 #DIV/0! 329.37 67.77

Temp. (°F)

Elapsed Time (min) Fuel Weight Remaining (lb) Flue Gas Composition (%) CO CO₂ O₂ Flue Gas Room Temp

Elapsed Time (min)	Fuel Weight Remaining (lb)	Flue Gas Composition (%) CO	CO ₂	O ₂	Flue Gas	Room Temp
0	9.20	0.18	5.01		334.0	66.0
5	8.70	0.51	13.19		357.0	65.0
10	8.20	0.33	13.34		400.0	65.0
15	7.50	0.52	14.94		456.0	66.0
20	6.80	0.81	15.64		479.0	66.0
25	6.00	1.40	16.55		495.0	66.0
30	5.20	1.64	17.27		500.0	67.0
35	4.30	1.87	17.89		510.0	66.0
40	3.60	1.80	17.88		504.0	67.0
45	2.90	0.99	17.65		507.0	67.0
50	2.40	0.61	14.17		448.0	67.0
55	2.00	0.42	12.95		387.0	69.0
60	1.70	0.22	11.81		353.0	70.0
65	1.50	0.37	10.73		326.0	68.0
70	1.30	0.70	9.38		299.0	69.0
75	1.20	0.81	9.00		281.0	68.0
80	1.10	1.05	8.43		265.0	69.0
85	1.00	1.12	7.95		254.0	69.0
90	0.90	0.90	8.05		252.0	69.0
95	0.80	1.19	7.47		244.0	69.0
100	0.70	1.21	7.68		235.0	69.0
105	0.60	1.21	7.80		233.0	69.0
110	0.50	1.29	7.61		231.0	69.0
115	0.50	1.40	7.06		230.0	69.0
120	0.40	1.45	7.06		225.0	69.0
125	0.30	1.57	6.24		219.0	68.0
130	0.20	1.66	6.18		217.0	68.0
135	0.20	1.72	6.25		216.0	68.0
140	0.10	1.67	6.21		213.0	68.0
145	0.00	1.74	6.12		211.0	68.0

ASTM E2780 Wood Heater Run Sheets

Client: Hearth & Home Project Number: 0135WS044E Run Number: 1
 Model: Aspen C3 Tracking Number: 2339 Date: 1/15/19
 Test Crew: W. Davis
 OMNI Equipment ID numbers: _____

Wood Heater Run Notes

Air Control Settings

Primary:

Secondary: fixed opening

fixed, single burn Rate stove.
 Non adjustable bi-metabolic thermostat
 located in the Air inlet.

Tertiary/Pilot: N/A

Fan: N/A

Preburn Notes

Time	Notes
0	10.5 lbs of preburn loaded on 2.0 lbs of coals. Door cracked open until 9.5 lbs Then preburn was started

Test Notes

Sketch test fuel configuration:

Start up procedures & Timeline:

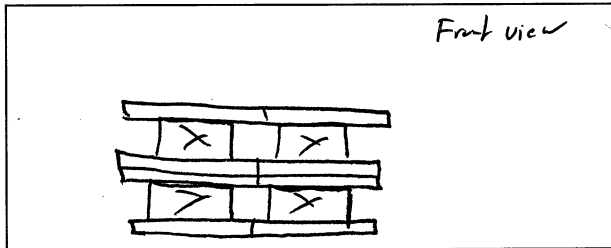

Bypass: N/A

Fuel loaded by: 50 seconds

Door closed at: 55 seconds

Primary air: Not adjustable, single burn Rate

Notes: _____

Time	Notes
60	Changed Front filter in tra. - A

Technician Signature: W. Davis

Date: 1/15/19

ASTM E2780 Wood Heater Run Sheets

Client: Hearth & Home Project Number: 0135WS044E Run Number: 1
 Model: Aspen C3 Tracking Number: 2339 Date: 1/15/19
 Test Crew: B Davis
 OMNI Equipment ID numbers: _____

Wood Heater Fuel Data

Fuel: Douglas fir, untreated and air dried, standard grade or better dimensional lumber

Pre-Burn Fuel

Calibration: Cal Value (1) = 12% Actual Reading 12
 Cal Value (2) = 22% Actual Reading 22

Piece:	Length:	Reading:	Piece:	Length:	Reading:
1	<u>96</u> in	<u>19.2</u>	7	<u>21.4</u> in	<u>19.1</u>
2	_____ in	<u>18.9</u>	8	<u>19.8</u> in	<u>21.4</u>
3	_____ in	_____	9	_____ in	_____
4	_____ in	_____	10	_____ in	_____
5	_____ in	_____	11	_____ in	_____
6	_____ in	_____	12	_____ in	_____

Total Pre-Burn Fuel Weight: 14.1 Pre-Burn Fuel Average Moisture: 19.97

Time (clock): 0810 Room Temperature (F): 68 Initials: BD

Test Fuel

Firebox Volume (ft³): 1.39 Test Fuel Piece Length (in): 16"
 Load Weight Range (lb): 8.8 - 9.73 - 10.7 Total Wet Fuel Load Weight (lb): 9.2
1.9 - 2.3

Fuel Type & Amount: 2 x 4: 4 4 x 4: 0
 * Weight (with spacers): 9.2 Weight (with spacers): NA

Piece:	Weight (lbs):	Moisture Readings (%DB):		Fuel Type:	
1	<u>1.8</u>	<u>19.8</u>	<u>18.9</u>	<u>19.1</u>	<u>2x4</u>
2	<u>1.8</u>	<u>19.4</u>	<u>19.5</u>	<u>20.0</u>	_____
3	<u>1.7</u>	<u>20.0</u>	<u>20.8</u>	<u>21.4</u>	_____
4	<u>1.9</u>	<u>19.8</u>	<u>20.0</u>	<u>21.4</u>	_____
5	_____	_____	_____	_____	_____
6	_____	_____	_____	_____	_____
7	_____	_____	_____	_____	_____

Spacer Moisture Readings (%DB)

<u>14.7</u>	<u>12.0</u>	<u>10.6</u>	<u>15.1</u>	_____	_____	_____
<u>9.2</u>	<u>14.4</u>	<u>9.8</u>	<u>10.0</u>	_____	_____	_____
<u>10.0</u>	<u>9.0</u>	<u>15.3</u>	<u>13.2</u>	_____	_____	_____
<u>13.6</u>	<u>9.2</u>	<u>12.4</u>	<u>15.1</u>	_____	_____	_____

Time (clock): 0915 Room Temperature (F): 69 Initials: BD

Technician Signature: BD Date: 1/15/19

ASTM E2780 Wood Heater Run Sheets

Client: Hearth & Home Project Number: 0135WS044E Run Number: 1
 Model: Aspen C3 Tracking Number: 2339 Date: 1/15/19
 Test Crew: B Davis
 OMNI Equipment ID numbers: 132, 650, 335, 336, 296-755, 637, 592, 594

Wood Heater Supplemental Data

Start Time: 12:34 Booth #: E1

Stop Time: 14:59

Stack Gas Leak Check:

Initial: good Final: good

Sample Train Leak Check:

A: 0.0 @ 7 "Hg
 B: 0.0 @ 8 "Hg

Calibrations: Span Gas CO₂: 17.06 CO: 4.29

	Pre Test		Post Test	
	Zero	Span	Zero	Span
Time	10:17	10:19	1515	1516
CO ₂	0.00	17.03	0.01	16.98
CO	-0.001	4.29	0.000	4.273

CO ppm 1 803 0 888 (0.091)

Air Velocity (ft/min): Initial: 250 Final: 250

Scale Audit (lbs): Initial: 10.0 Final: 10.0

Pitot Tube Leak Test: Initial: good Final: good

Stack Diameter (in): 6"

Induced Draft: 0.0

% Smoke Capture: 100%

Flue Pipe Cleaned Prior to First Test in Series:

Date: 1/15/19 Initials: BA

	Initial	Middle	Ending
P _b (in/Hg)	29.91		29.84
RH (%)	26%		25
Ambient (°F)	66		68

Tunnel Traverse		
Microtector Reading	dP (in H ₂ O)	T(°F)
	.040	91
	.054	91
	.048	90
	.038	90
	.034	87
	.044	87
	.056	87
	.050	87
	.036	87
Center:		
	.054	91

Background Filter Volume: N/A

Tunnel Static Pressure (in H ₂ O):	
Beginning of Test	End of Test
- .21	- .21

Technician Signature: [Signature]

Date: 1/15/19

Run 2

Wood Heater Preburn Data - ASTM E2780

Run: **2**
 Manufacturer: Hearth & Home
 Model: Aspen C3
 Tracking No.: 2339
 Project No.: 0135WS044E
 Test Date: 1/16/2019
 Beginning Clock Time: 10:09

Coal Bed
 Range **1.8** **2.3**
 (lb): (min) (max)

Technician Signature: 

Elapsed Time (min)	Scale (lb)	Stack Draft (in H ₂ O)	Temperatures (°F)							Stack	Ambient
			FB Top	FB Bottom	FB Back	FB Left	FB Right	Avg. Firebox Surface			
0	9.3	-0.075	575	97	117	257	270	263.2	585	67	
1	9.2	-0.071	617	98	117	261	272	273	533	67	
2	9	-0.07	641	100	117	264	276	279.6	503	67	
3	8.9	-0.069	658	101	118	268	279	284.8	499	68	
4	8.7	-0.07	675	103	118	272	283	290.2	501	68	
5	8.6	-0.07	691	104	119	276	287	295.4	501	68	
6	8.4	-0.07	709	105	119	280	290	300.6	505	68	
7	8.2	-0.07	719	107	120	284	294	304.8	506	68	
8	8.1	-0.07	733	108	121	289	298	309.8	510	68	
9	7.9	-0.07	746	109	122	293	303	314.6	512	68	
10	7.8	-0.07	756	111	123	297	307	318.8	513	68	
11	7.6	-0.069	767	112	125	302	312	323.6	505	69	
12	7.5	-0.068	766	113	126	306	317	325.6	499	69	
13	7.3	-0.068	768	114	127	310	322	328.2	497	69	
14	7.2	-0.068	771	115	128	314	327	331	498	69	
15	7	-0.07	775	116	129	318	332	334	500	69	
16	6.9	-0.069	780	117	130	322	337	337.2	503	70	
17	6.7	-0.07	785	118	131	325	342	340.2	506	69	
18	6.6	-0.071	792	119	132	329	346	343.6	511	69	
19	6.4	-0.071	801	120	134	333	350	347.6	518	69	
20	6.3	-0.073	813	121	135	336	354	351.8	530	69	
21	6.1	-0.073	829	122	136	340	358	357	543	69	
22	5.9	-0.072	840	123	137	343	362	361	543	69	
23	5.8	-0.072	848	124	139	346	366	364.6	543	69	
24	5.6	-0.073	850	125	140	350	369	366.8	538	69	
25	5.5	-0.071	853	126	142	353	373	369.4	538	69	
26	5.4	-0.07	852	127	143	356	377	371	529	70	
27	5.2	-0.071	848	128	145	360	380	372.2	522	69	
28	5.1	-0.07	843	129	147	363	384	373.2	514	69	
29	5	-0.07	834	130	148	367	387	373.2	506	69	
30	4.9	-0.069	830	131	150	370	391	374.4	505	69	
31	4.7	-0.069	824	132	152	374	395	375.4	503	69	
32	4.6	-0.069	823	133	154	377	398	377	498	70	
33	4.5	-0.068	817	134	156	381	402	378	493	68	
34	4.4	-0.068	806	135	158	385	406	378	484	69	
35	4.3	-0.066	791	136	160	389	409	377	472	69	
36	4.2	-0.065	778	137	162	393	413	376.6	462	68	
37	4.1	-0.065	765	138	164	398	417	376.4	453	68	
38	4	-0.065	754	139	166	402	420	376.2	449	68	
39	3.9	-0.063	744	140	169	406	424	376.6	445	69	
40	3.8	-0.063	736	141	171	410	428	377.2	439	68	
41	3.7	-0.064	728	142	175	414	431	378	433	69	
42	3.6	-0.062	720	143	178	419	434	378.8	429	68	
43	3.5	-0.063	711	144	182	423	437	379.4	424	69	
44	3.4	-0.061	706	145	185	426	440	380.4	419	68	
45	3.3	-0.061	701	146	189	430	443	381.8	419	68	
46	3.2	-0.062	701	147	192	434	446	384	421	68	
47	3.1	-0.06	701	148	196	437	448	386	418	69	
48	3.1	-0.059	701	150	199	440	450	388	420	69	
49	3	-0.059	695	151	202	443	452	388.6	410	68	
50	2.9	-0.059	684	152	205	445	454	388	403	68	
51	2.8	-0.058	675	153	208	447	455	387.6	399	68	
52	2.7	-0.056	666	155	211	449	456	387.4	393	68	
53	2.7	-0.057	660	156	214	451	457	387.6	388	70	

Wood Heater Preburn Data - ASTM E2780

Run: **2**

Manufacturer: Hearth & Home
 Model: Aspen C3
 Tracking No.: 2339
 Project No.: 0135WS044E
 Test Date: 1/16/2019
 Beginning Clock Time: 10:09

Coal Bed		
Range	1.8	2.3
(lb):	(min)	(max)

Technician Signature: _____

Elapsed Time (min)	Scale (lb)	Stack Draft (in H ₂ O)	Temperatures (°F)							Stack	Ambient
			FB Top	FB Bottom	FB Back	FB Left	FB Right	Avg. Firebox Surface			
54	2.6	-0.056	654	157	216	452	458	387.4	382	69	
55	2.6	-0.055	645	158	219	454	459	387	377	68	
56	2.5	-0.055	636	159	220	454	459	385.6	371	69	
57	2.4	-0.054	628	160	222	455	459	384.8	368	68	
58	2.4	-0.054	622	162	223	455	459	384.2	364	68	
59	2.3	-0.052	616	163	225	455	459	383.6	356	69	
60	2.3	-0.053	609	164	226	455	459	382.6	349	68	
61	2.2	-0.051	603	165	228	454	459	381.8	343	69	
62	2.2	-0.051	596	166	229	454	458	380.6	342	68	
63	2.1	-0.05	589	167	231	453	458	379.6	335	69	
64	2.1	-0.049	581	168	232	452	457	378	330	68	
65	2	-0.048	572	169	234	451	457	376.6	322	68	
66	2	-0.047	562	170	235	450	456	374.6	316	68	
67	2	-0.047	553	171	237	449	455	373	310	68	
68	1.9	-0.046	545	172	239	448	454	371.6	305	68	

Wood Heater Test Fuel Data - ASTM E2780

Manufacturer: **Hearth & Home**
 Model: **Aspen C3**
 Tracking No.: **2339**
 Project No.: **0135WS044E**
 Test Date: **1/16/2019**
 Run No.: **2**

Firebox Volume (ft ³):	1.25
Fuel Piece Length (in):	16
2x4 Crib Weight (lb):	9
4x4 Crib Weight (lb):	

Total Fuel Weight (Dry Basis, lb):	7.6	
Fuel Density (lb/ft ³ , Dry Basis):	30.05	OK
Loading Density (lb/ft ³ , Wet Basis):	7.20	OK
2x4 Percentage:	N/A	N/A

Coal Bed Range (20-25%): **1.8 - 2.25**

Test Fuel Piece	Weight (lb)	Size	Readings (Dry Basis %)			Dry Weight (lb)
1	1.7	2"x 4"	18.7	19.6	20.6	1.42
2	1.8	2"x 4"	21.7	19.4	18.9	1.50
3	1.7	2"x 4"	19.3	20.6	20.1	1.42
4	1.8	2"x 4"	18.8	19.7	20.1	1.51

Spacer Readings (Dry Basis %)			
12.1	9.4		
10.2	10.6		
13.2	13.8		
14.2			
15.2			
13.1			
8.9			
9.4			
9.9			
11.5			
13.4			
14.8			
12.1			

Technician Signature:

ASTM E2780 Wood Heater Run Sheets

Client: Hearth & Home Project Number: 0135WS044E Run Number: 2
 Model: Aspen C3 Tracking Number: 2339 Date: 1/16/19
 Test Crew: B. Davis
 OMNI Equipment ID numbers: _____

Wood Heater Run Notes

Air Control Settings

Primary:

Secondary: Fixed

Fixed, single burn Rate Stove.
 Non-Adjustable bi-metallic thermostat
 Located in Air Inlet Tube.

Tertiary/Pilot: N/A

Fan: N/A

Preburn Notes

Time	Notes
68	10.2 pounds of preburn loaded on 20 lbs of coals. Door cracked open until 9.5 lbs the pre burn was started
69	Levelled coal bed

Test Notes

Sketch test fuel configuration:

Start up procedures & Timeline:

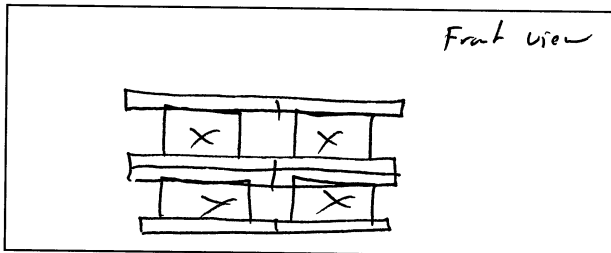

Bypass: N/A
 Fuel loaded by: 40 seconds
 Door closed at: 60 seconds
 Primary air: Not Adjustable

Notes: N/A

Time	Notes
17	During loading the baffle was impacted by a fuel piece, this caused a component of the baffle system to move out of place and change the angle of the assembly. Since the 5 minute start up time had elapsed, the door could not be opened to correct the issue. Test was stopped.

Technician Signature: B. Davis

Date: 1/16/19

ASTM E2780 Wood Heater Run Sheets

Client: Hearth & Home Project Number: 0135WS044E Run Number: 2
 Model: Aspen C3 Tracking Number: 2339 Date: 1/16/19
 Test Crew: BDO/As
 OMNI Equipment ID numbers: _____

Wood Heater Fuel Data

Fuel: Douglas fir, untreated and air dried, standard grade or better dimensional lumber

Pre-Burn Fuel

Calibration: Cal Value (1) = 12% Actual Reading 12
 Cal Value (2) = 22% Actual Reading 22

Piece:	Length:	Reading:	Piece:	Length:	Reading:
1	<u>96</u> in	<u>21.4</u>	7	_____ in	_____
2	_____ in	<u>19.7</u>	8	_____ in	_____
3	_____ in	<u>20.4</u>	9	_____ in	_____
4	_____ in	_____	10	_____ in	_____
5	_____ in	_____	11	_____ in	_____
6	_____ in	_____	12	_____ in	_____

Total Pre-Burn Fuel Weight: 10.2 Pre-Burn Fuel Average Moisture: 20.5
 Time (clock): 0920 Room Temperature (F): 68 Initials: As

Test Fuel

Firebox Volume (ft³): 1.39 Test Fuel Piece Length (in): 16"
 Load Weight Range (lb): 8.8-9.73-10.7 Total Wet Fuel Load Weight (lb): 9.0

Fuel Type & Amount: 2 x 4: 4 4 x 4: 1/4
 Weight (with spacers): 9.0 Weight (with spacers): _____

Piece:	Weight (lbs):	Moisture Readings (%DB):				Fuel Type:
1	<u>1.7</u>	<u>18.7</u>	<u>19.6</u>	<u>20.6</u>	<u>2x4</u>	
2	<u>1.8</u>	<u>21.7</u>	<u>19.4</u>	<u>18.9</u>	↓	
3	<u>1.7</u>	<u>19.3</u>	<u>20.6</u>	<u>20.1</u>	↓	
4	<u>1.8</u>	<u>18.8</u>	<u>19.7</u>	<u>20.1</u>	↓	
5	_____	_____	_____	_____	_____	
6	_____	_____	_____	_____	_____	
7	_____	_____	_____	_____	_____	

Spacer Moisture Readings (%DB)

<u>12.1</u>	<u>15.2</u>	<u>9.9</u>	<u>12.1</u>	_____	_____
<u>10.2</u>	<u>13.1</u>	<u>11.5</u>	<u>9.4</u>	_____	_____
<u>13.2</u>	<u>8.9</u>	<u>13.4</u>	<u>10.6</u>	_____	_____
<u>14.2</u>	<u>9.4</u>	<u>14.8</u>	<u>13.8</u>	_____	_____

Time (clock): 1000 Room Temperature (F): 69 Initials: As

Technician Signature: [Signature] Date: 1/16/19

ASTM E2780 Wood Heater Run Sheets

Client: Hearth & Home Project Number: 0135WS044E Run Number: 2
 Model: Aspen C3 Tracking Number: 2339 Date: 1/16/19
 Test Crew: R Davis
 OMNI Equipment ID numbers: _____

Wood Heater Supplemental Data

Start Time: 11:18 Booth #: E1

Stop Time: _____

Stack Gas Leak Check:

Initial: good Final: _____

Sample Train Leak Check:

A: _____ @ _____ "Hg
 B: _____ @ _____ "Hg

Calibrations: Span Gas CO₂: 17.06 CO: 4.29

	Pre Test		Post Test	
	Zero	Span	Zero	Span
Time	<u>1050</u>	<u>16.96</u> 1050		
CO ₂	<u>0.00</u>	<u>4.27</u> 16.96		
CO	<u>-0.001</u>	<u>4.27</u>		

Air Velocity (ft/min): Initial: 250 Final: _____

Scale Audit (lbs): Initial: 10.0 Final: _____

Pitot Tube Leak Test: Initial: 0.0 Final: _____

Stack Diameter (in): 6"

Induced Draft: 0.0

% Smoke Capture: 100%

Flue Pipe Cleaned Prior to First Test in Series:

Date: 1/15/19 Initials: RL

	Initial	Middle	Ending
P _b (in/Hg)	<u>29.81</u>		
RH (%)	<u>24</u>		
Ambient (°F)			

Tunnel Traverse		
Microtector Reading	dP (in H ₂ O)	T(°F)
	<u>.040</u>	<u>89</u>
	<u>.054</u>	<u>90</u>
	<u>.050</u>	<u>90</u>
	<u>.038</u>	<u>89</u>
	<u>.036</u>	<u>88</u>
	<u>.048</u>	<u>88</u>
	<u>.054</u>	<u>88</u>
	<u>.038</u>	<u>88</u>
Center:		
	<u>.054</u>	<u>90</u>

Background Filter Volume: N/A

Tunnel Static Pressure (in H ₂ O):	
Beginning of Test	End of Test
<u>-.21</u>	

Technician Signature: [Signature]

Date: 1/16/19

Run 3

Wood Heater Test Results - ASTM E2780 / ASTM E2515

Manufacturer: Hearth & Home
 Model: Aspen C3
 Project No.: 0135WS044E
 Tracking No.: 2339
 Run: 3
 Test Date: 01/17/19

Burn Rate	1.24 kg/hr dry
Average Tunnel Temperature	84 degrees Fahrenheit
Average Gas Velocity in Dilution Tunnel - vs	14.24 feet/second
Average Gas Flow Rate in Dilution Tunnel - Qsd	9479.4 dscf/hour
Average Delta p	0.054 inches H2O
Total Time of Test	160 minutes

	AMBIENT	SAMPLE TRAIN 1	SAMPLE TRAIN 2	FIRST HOUR FILTER (TRAIN 1)
Total Sample Volume - Vm	0.000 cubic feet	26.016 cubic feet	26.054 cubic feet	9.699 cubic feet
Average Gas Meter Temperature	67 degrees Fahrenheit	77 degrees Fahrenheit	79 degrees Fahrenheit	77 degrees Fahrenheit
Total Sample Volume (Standard Conditions) - Vmstd	0.000 dscf	25.038 dscf	24.943 dscf	9.334 dscf
Total Particulates - m _p	0 mg	6.1 mg	5.6 mg	0 mg
Particulate Concentration (dry-standard) - C _p /C _s	0.000000 grams/dscf	0.00024 grams/dscf	0.00022 grams/dscf	0.00000 grams/dscf
Total Particulate Emissions - E _T	0.00 grams	6.16 grams	5.68 grams	0.00 grams
Particulate Emission Rate	0.00 grams/hour	2.31 grams/hour	2.13 grams/hour	0.00 grams/hour
Emissions Factor		1.86 g/kg	1.72 g/kg	0.00 g/kg
Difference from Average Total Particulate Emissions		0.24 grams	0.24 grams	

Dual Train Comparison Results Are Acceptable

FINAL AVERAGE RESULTS	
Complete Test Run	
Total Particulate Emissions - E _T	5.92 grams
Particulate Emission Rate	2.22 grams/hour
Emissions Factor	1.79 grams/kg
First Hour Emissions	
Total Particulate Emissions - E _T	0.00 grams
Particulate Emission Rate	0.00 grams/hour
Emissions Factor	0.00 grams/kg

QUALITY CHECKS	
Filter Temps < 90 °F	OK
Filter Face Velocity (47 mm)	OK
Dryer Exit Temp < 80F	OK
Leakage Rate	OK
Ambient Temp (55-90°F)	OK
Negative Probe Weight Eval.	OK
Pro-Rate Variation	OK
Stove Surface ΔT	OK

Technician Signature: 

Wood Heater Preburn Data - ASTM E2780

Run: 3
 Manufacturer: Hearth & Home
 Model: Aspen C3
 Tracking No.: 2339
 Project No.: 0135WS044E
 Test Date: 43482
 Beginning Clock Time: 10:19

Coal Bed
 Range **1.8** **2.2**
 (lb): (min) (max)

Technician Signature: 

Elapsed Time (min)	Scale (lb)	Stack Draft (in H ₂ O)	Temperatures (°F)							Stack	Ambient
			FB Top	FB Bottom	FB Back	FB Left	FB Right	Avg. Firebox Surface			
0	9.2	-0.071	692	89	132	268	288	293.8	547	69	
1	9	-0.069	704	91	132	271	292	298	515	69	
2	8.9	-0.068	712	92	132	274	297	301.4	503	70	
3	8.7	-0.069	722	93	132	278	301	305.2	501	70	
4	8.5	-0.069	728	95	132	281	305	308.2	499	70	
5	8.4	-0.07	738	96	132	284	308	311.6	504	70	
6	8.2	-0.071	749	98	132	287	312	315.6	511	70	
7	8	-0.073	762	99	132	290	315	319.6	521	70	
8	7.8	-0.073	778	101	132	294	318	324.6	529	70	
9	7.7	-0.073	790	102	133	297	321	328.6	534	70	
10	7.5	-0.075	802	104	134	301	323	332.8	537	70	
11	7.3	-0.074	813	105	135	304	326	336.6	545	70	
12	7.1	-0.075	822	107	136	308	329	340.4	548	70	
13	6.9	-0.073	834	109	138	312	332	345	550	70	
14	6.7	-0.074	840	110	139	316	334	347.8	549	69	
15	6.6	-0.074	848	112	140	320	337	351.4	550	70	
16	6.4	-0.073	852	114	141	325	340	354.4	550	70	
17	6.2	-0.074	853	115	143	329	344	356.8	545	69	
18	6.1	-0.074	856	117	144	334	347	359.6	545	70	
19	5.9	-0.074	857	119	145	338	349	361.6	539	69	
20	5.8	-0.073	853	121	147	342	352	363	531	70	
21	5.6	-0.071	846	122	149	347	355	363.8	522	69	
22	5.5	-0.071	840	124	152	351	357	364.8	518	69	
23	5.3	-0.072	836	126	154	355	360	366.2	512	69	
24	5.2	-0.071	830	127	157	359	362	367	508	69	
25	5.1	-0.07	825	129	159	362	365	368	504	69	
26	4.9	-0.07	820	130	162	366	368	369.2	496	69	
27	4.8	-0.071	814	132	165	370	370	370.2	490	70	
28	4.7	-0.069	807	133	168	373	372	370.6	486	69	
29	4.6	-0.07	802	135	170	377	375	371.8	484	68	
30	4.5	-0.068	797	136	173	381	378	373	476	69	
31	4.4	-0.068	791	138	176	385	381	374.2	471	69	
32	4.2	-0.068	786	140	178	388	384	375.2	467	68	
33	4.1	-0.068	782	141	181	392	387	376.6	465	69	
34	4	-0.067	778	142	184	396	389	377.8	466	69	
35	3.9	-0.066	775	144	186	399	392	379.2	461	70	
36	3.8	-0.066	770	145	189	403	394	380.2	458	69	
37	3.7	-0.065	763	147	192	406	397	381	449	69	
38	3.6	-0.065	754	148	195	410	400	381.4	440	68	
39	3.5	-0.064	744	150	199	413	403	381.8	433	68	
40	3.4	-0.062	733	151	202	416	405	381.4	428	68	
41	3.3	-0.062	722	153	205	419	407	381.2	420	69	
42	3.2	-0.062	711	154	208	422	411	381.2	416	68	
43	3.1	-0.061	702	156	212	425	413	381.6	412	68	
44	3.1	-0.061	694	157	215	427	416	381.8	407	68	
45	3	-0.059	685	159	218	429	419	382	400	68	
46	2.9	-0.058	678	160	220	432	421	382.2	396	69	
47	2.8	-0.058	671	162	223	434	424	382.8	389	69	
48	2.8	-0.058	663	163	226	436	426	382.8	384	68	
49	2.7	-0.057	655	165	228	437	428	382.6	378	68	
50	2.6	-0.057	648	166	231	439	430	382.8	376	68	
51	2.5	-0.056	640	168	234	440	432	382.8	374	68	
52	2.5	-0.054	631	169	236	442	434	382.4	362	68	
53	2.4	-0.052	619	171	239	443	435	381.4	353	68	

Wood Heater Preburn Data - ASTM E2780

Run: 3

Manufacturer: Hearth & Home
 Model: Aspen C3
 Tracking No.: 2339
 Project No.: 0135WS044E
 Test Date: 43482
 Beginning Clock Time: 10:19

Coal Bed		
Range	1.8	2.2
(lb):	(min)	(max)

Technician Signature: _____

Elapsed Time (min)	Scale (lb)	Stack Draft (in H ₂ O)	Temperatures (°F)							Stack	Ambient
			FB Top	FB Bottom	FB Back	FB Left	FB Right	Avg. Firebox Surface			
54	2.4	-0.051	610	172	241	444	436	380.6	348	68	
55	2.3	-0.052	600	174	243	445	438	380	341	68	
56	2.3	-0.051	592	175	245	447	440	379.8	337	69	
57	2.2	-0.05	584	177	247	447	441	379.2	329	68	
58	2.2	-0.048	575	178	249	448	442	378.4	320	68	
59	2.2	-0.048	565	180	251	448	444	377.6	318	68	
60	2.1	-0.047	558	181	253	449	445	377.2	314	68	
61	2.1	-0.046	548	183	255	449	445	376	305	68	
62	2	-0.044	537	184	257	448	446	374.4	295	67	
63	2	-0.043	525	186	259	447	446	372.6	287	67	
64	2	-0.042	514	187	261	446	447	371	282	67	
65	2	-0.041	504	189	263	445	446	369.4	279	68	
66	1.9	-0.041	496	190	264	443	445	367.6	274	68	

Wood Heater Test Data - ASTM E2780 / ASTM E2515

Run: 3

Manufacturer: Hearth & Home
 Model: Aspen C3

Tracking No.: 2339
 Project No.: 0135WS044E
 Test Date: 17-Jan-19
 Beginning Clock Time: 11:27

Total Sampling Time: 160 min
 Recording Interval: 5 min

Background Sample Volume: _____ cubic feet

Meter Box Y Factor: 0.986 (1) 0.985 (2) _____ (Amb)

Barometric Pressure: Begin Middle End Average
29.56 _____ 29.65 _____ 29.61 "Hg

OMNI Equipment Numbers: _____

PM Control Modules: 335, 336

Dilution Tunnel MW(dry): 29.00 lb/lb-mole
 Dilution Tunnel MW(wet): 28.78 lb/lb-mole
 Dilution Tunnel H₂O: 2.00 percent
 Dilution Tunnel Static: -0.210 "H₂O
 Tunnel Area: 0.19635 ft²
 Pitot Tube Cp: 0.99

Avg. Tunnel Velocity: 14.24 ft/sec.
 Initial Tunnel Flow: 160.2 scfm
 Average Tunnel Flow: 158.0 scfm

Post-Test Leak Check (1): 0.000 cfm @ 7 in. Hg
 Post-Test Leak Check (2): 0.000 cfm @ 7 in. Hg

Average Test Piece Fuel Moisture: 21.00 Dry Basis %

Technician Signature: B. K.

	Pt.1	Pt.2	Pt.3	Pt.4	Pt.5	Pt.6	Pt.7	Pt.8	Center	
Initial dP	0.040	0.054	0.050	0.040	0.038	0.056	0.054	0.040	0.058	"H ₂ O
Temp:	91	91	91	90	90	90	90	90	91	°F
	V _{strav} <u>14.84</u> ft/sec			V _{scnt} <u>16.41</u> ft/sec			F _p <u>0.904</u>			

Elapsed Time (min)	Particulate Sampling Data											Fuel Weight (lb)		Temperature Data (°F)										Stack Gas Data								
	Gas Meter 1 (ft³)	Gas Meter 2 (ft³)	Sample Rate 1 (cfm)	Sample Rate 2 (cfm)	Orifice dH 1 ("H ₂ O)	Meter 1 Temp (°F)	Meter 1 Vacuum ("Hg)	Orifice dH 2 ("H ₂ O)	Meter 2 Temp (°F)	Meter 2 Vacuum ("Hg)	Dilution Tunnel ("H ₂ O)	Dilution Tunnel Center dP	Pro. Rate 1	Pro. Rate 2	Scale Reading	Weight Change	Firebox Top	Firebox Bottom	Firebox Back	Firebox Left	Firebox Right	Avg. Stove Surface Temp	Stack	Filter 1	Dryer Exit 1	Filter 2	Dryer Exit 2	Ambient	Draft ("H ₂ O)	CO ₂ (%)	CO (%)	
0	0.000	0.000			0.85	72	1.66	0.05	74	1.1	96	0.057			8.8		467	196	278	440	442	365		295	68	66	69	60	68	-0.039	2.51	0.39
5	0.800	0.808	0.16	0.16	1.36	73	1.98	1.10	74	1.1	84	0.058	96	97	8.3	-0.5	415	203	250	423	431	344		264	69	73	70	66	67	-0.044	6.53	0.74
10	1.611	1.622	0.16	0.16	1.36	73	1.98	1.09	74	1.1	87	0.054	101	101	7.8	-0.5	480	205	207	399	406	339		355	69	73	70	66	67	-0.055	11.34	0.48
15	2.420	2.434	0.16	0.16	1.35	73	1.97	1.09	75	1.1	89	0.052	103	103	7.2	-0.6	553	206	182	382	387	342		401	69	73	70	66	67	-0.061	14.26	0.4
20	3.228	3.244	0.16	0.16	1.35	74	1.97	1.08	75	1.1	91	0.055	100	100	6.6	-0.6	610	205	168	376	380	348		432	70	74	71	67	67	-0.065	15.75	0.45
25	4.035	4.054	0.16	0.16	1.34	74	1.97	1.08	76	1.1	93	0.053	102	102	5.9	-0.7	663	201	161	375	383	357		449	70	74	71	68	67	-0.066	16.39	0.28
30	4.842	4.864	0.16	0.16	1.34	75	1.98	1.08	77	1.1	95	0.053	102	102	5.2	-0.7	707	198	160	377	391	367		458	70	75	72	68	67	-0.067	16.07	0.46
35	5.650	5.676	0.16	0.16	1.35	76	1.98	1.08	78	1.1	97	0.055	100	100	4.5	-0.7	757	194	164	385	400	380		487	71	76	72	69	67	-0.069	17.87	1.09
40	6.458	6.487	0.16	0.16	1.34	76	1.98	1.08	78	1.1	97	0.055	100	100	3.7	-0.8	782	190	170	397	413	390		484	71	76	72	70	67	-0.069	17.34	1.14
45	7.267	7.297	0.16	0.16	1.34	77	1.98	1.08	79	1.1	97	0.052	103	103	3.1	-0.6	799	187	179	413	427	401		483	71	77	73	70	67	-0.067	16.96	0.46
50	8.077	8.109	0.16	0.16	1.35	77	1.98	1.08	79	1.1	95	0.058	97	97	2.6	-0.5	766	184	189	428	441	402		435	71	77	73	71	67	-0.061	14.33	0.17
55	8.887	8.921	0.16	0.16	1.35	78	1.98	1.09	80	1.1	91	0.057	98	98	2.2	-0.4	680	182	198	439	452	390		383	71	78	72	71	67	-0.056	12.48	0.32
60	9.699	9.735	0.16	0.16	1.35	78	1.97	1.08	80	1.1	89	0.053	101	101	2.0	-0.2	612	181	206	447	457	381		344	71	78	72	72	68	-0.050	10.81	0.52
65	10.512	10.548	0.16	0.16	1.35	78	1.97	1.09	81	1.1	85	0.054	100	100	1.7	-0.3	552	180	216	450	457	371		309	71	78	72	72	67	-0.046	9.81	0.44
70	11.326	11.363	0.16	0.16	1.35	78	1.98	1.09	81	1.1	84	0.055	99	99	1.5	-0.2	519	180	224	448	453	365		298	70	78	72	72	67	-0.044	9.69	0.31
75	12.140	12.178	0.16	0.16	1.35	78	1.97	1.08	81	1.1	83	0.058	97	96	1.4	-0.1	492	180	229	444	446	358		279	70	78	71	72	67	-0.041	8.92	0.4
80	12.955	12.993	0.16	0.16	1.35	79	1.97	1.08	81	1.1	81	0.055	99	99	1.3	-0.1	464	180	231	437	438	350		261	70	77	71	72	67	-0.039	7.46	1.11
85	13.771	13.810	0.16	0.16	1.35	79	1.97	1.09	81	1.1	80	0.055	99	99	1.2	-0.1	435	180	233	427	427	340		245	69	77	70	72	67	-0.036	7.04	1.32
90	14.586	14.626	0.16	0.16	1.36	79	1.97	1.09	81	1.1	79	0.054	100	100	1.1	-0.1	415	180	235	416	417	333		239	69	76	70	72	67	-0.034	7.61	1.03
95	15.402	15.443	0.16	0.16	1.36	78	1.97	1.09	80	1.1	78	0.056	98	98	1.0	-0.1	404	180	239	407	408	328		236	69	76	70	71	66	-0.034	7.61	1.06
100	16.219	16.259	0.16	0.16	1.36	78	1.97	1.09	80	1.1	78	0.054	100	100	0.9	-0.1	394	180	241	399	401	323		229	68	75	69	71	66	-0.033	7.06	1.24
105	17.034	17.075	0.16	0.16	1.36	78	1.97	1.09	80	1.1	77	0.055	99	99	0.8	-0.1	383	180	243	392	395	319		228	68	75	69	71	67	-0.032	7.05	1.21
110	17.851	17.892	0.16	0.16	1.36	78	1.96	1.08	80	1.1	77	0.055	99	99	0.8	0	374	180	244	385	390	315		223	68	74	69	70	66	-0.031	7.06	1.24
115	18.668	18.708	0.16	0.16	1.36	78	1.96	1.09	80	1.1	77	0.051	103	103	0.7	-0.1	368	180	244	379	387	312		219	68	74	69	70	66	-0.030	6.86	1.35
120	19.483	19.525	0.16	0.16	1.36	78	1.97	1.09	80	1.1	77	0.053	101	101	0.6	-0.1	363	179	245	373	383	309		215	67	74	68	70	67	-0.030	6.43	1.49
125	20.300	20.341	0.16	0.16	1.36	78	1.97	1.09	80	1.1	76	0.054	100	100	0.5	-0.1	353	180	245	367	380	305		207	67	73	68	69	66	-0.029	5.98	1.58
130	21.117	21.157	0.16	0.16	1.37	78	1.97	1.08	79	1.1	75	0.053	101	101	0.5	0	345	180	243	362	375	301		207	67	73	68	69	67	-0.029	5.96	1.56
135	21.933	21.974	0.16	0.16	1.37	78	1.97	1.08	79	1.1	75	0.054	100	100	0.4	-0.1	337	180	242	357	371	297		202	67	73	68	69	66	-0.028	5.36	1.63
140	22.751	22.790	0.16	0.16	1.36	78	1.97	1.08	79	1.1	75	0.053	101	101	0.3	-0.1	331	179	241	351	366	294		199	67	72	68	69	66	-0.028	6.22	1.31
145	23.566	23.606	0.16	0.16	1.36	77	1.97	1.08	79	1.1	75	0.053	101	101	0.3	0	330	179	240	348	362	292		200	67	72	68	69	66	-0.028	6.26	1.2
150	24.383	24.422	0.16	0.16	1.36	77	1.97	1.08	79	1.1	75	0.049	105	105	0.2	-0.1	328	178	241	345	359	290		198	67	72	68	68	66	-0.027	6.22	1.29
155	25.200	25.238	0.16	0.16	1.36	77	1.96	1.09	79	1.1	75	0.056	98	98	0.2	0	327	177	241	342	357	289		199	67	71	68	68	67	-0.027	5.92	1.38
160	26.016	26.054	0.16	0.16	1.36	77	1.97	1.08	79	1.1	74	0.053	101	100	0.0	-0.2	322	177	241	340	355	287		195	67	71	67	68	66	-0.027	4.88	1.59
Avg/Tot	26.016	26.054	0.16	0.16	1.34	77			1.05	79		84	0.054	100	100							77.6										

Wood Heater Test Fuel Data - ASTM E2780

Manufacturer: **Hearth & Home**
 Model: **Aspen C3**
 Tracking No.: **2339**
 Project No.: **0135WS044E**
 Test Date: **1/17/2019**
 Run No.: **3**

Firebox Volume (ft ³):	1.25
Fuel Piece Length (in):	16
2x4 Crib Weight (lb):	8.8
4x4 Crib Weight (lb):	

Total Fuel Weight (Dry Basis, lb):	7.3	
Fuel Density (lb/ft ³ , Dry Basis):	29.32	OK
Loading Density (lb/ft ³ , Wet Basis):	7.04	OK
2x4 Percentage:	N/A	N/A

Coal Bed Range (20-25%): **1.76 - 2.2**

Test Fuel Piece	Weight (lb)	Size	Readings (Dry Basis %)			Dry Weight (lb)
1	1.7	2"x 4"	20.0	19.0	22.0	1.41
2	1.9	2"x 4"	22.4	22.5	22.3	1.55
3	1.7	2"x 4"	21.5	21.7	19.1	1.41
4	1.6	2"x 4"	23.1	19.5	18.9	1.33

Spacer Readings (Dry Basis %)			
16.9	22.6		
19.7	22.2		
20.6	12.3		
18.7			
21.3			
23.9			
16.7			
24.5			
19.8			
18.0			
21.5			
11.8			
23.9			

Technician Signature: 

Wood Heater Lab Data - ASTM E2780 / ASTM E2515

Manufacturer: Hearth & Home Equipment Numbers: 23, 131, 343
 Model: Aspen C3
 Tracking No.: 2339
 Project No.: 0135WS044E
 Run #: 3
 Date: 1/17/19

TRAIN 1 (First Hour emissions)

Sample Component	Reagent	Filter, Probe or Dish #	Weights		
			Final, mg	Tare, mg	Particulate, mg
B. Front filter catch	Filter		0.0	0.0	0.0
C. Rear filter catch	Filter				0.0
D. Probe catch*	Probe				0.0
E. Filter seals catch*	Seals				0.0

Sub-Total Total Particulate, mg: 0.0

TRAIN 1 (Post First Hour Change-out)

Sample Component	Reagent	Filter, Probe or Dish #	Weights		
			Final, mg	Tare, mg	Particulate, mg
B. Front filter catch	Filter	D650	125.8	122.0	3.8
C. Rear filter catch	Filter	D327	112.9	112.5	0.4
D. Probe catch*	Probe	24	114127.1	114126.5	0.6
E. Filter seals catch*	Seals	R713	3393.2	3391.9	1.3

Sub-Total Total Particulate, mg: 6.1

Train 1 Aggregate Total Particulate, mg: 6.1

TRAIN 2

Sample Component	Reagent	Filter, Probe or Dish #	Weights		
			Final, mg	Tare, mg	Particulate, mg
A. Front filter catch	Filter	D529	116.8	112.6	4.2
B. Rear filter catch	Filter	D530	112.8	112.8	0.0
C. Probe catch*	Probe	25	114299.1	114298.7	0.4
D. Filter seals catch*	Seals	R714	3535.1	3534.1	1.0

Total Particulate, mg: 5.6

AMBIENT

Sample Component	Reagent	Filter # or Probe #	Weights		
			Final, mg	Tare, mg	Particulate, mg
A. Front filter catch*	Filter				0.0

Total Particulate, mg: 0.0

*Particulate catch that results in a negative number, is assumed to be zero for probes and seals, negative numbers for filters are assumed to be part of the seal weight.

Component	Equations:
A. Front filter catch	Final (mg) - Tare (mg) = Particulate, mg
B. Rear filter catch	Final (mg) - Tare (mg) = Particulate, mg
C. Probe catch	Final (mg) - Tare (mg) = Particulate, mg

Technician Signature: 

OMNI Test Laboratories

Manufacturer: Hearth & Home
Model: Aspen C3
Date: 01/17/19
Run: 3
Control #: 0135WS044E
Test Duration: 160
Output Category: 3

Technicians: 

Test Results in Accordance with CSA B415.1-09

	HHV Basis	LHV Basis
Overall Efficiency	75.0%	81.2%
Combustion Efficiency	94.9%	94.9%
Heat Transfer Efficiency	79%	85.5%

Output Rate (kJ/h)	18,384	17,439	(Btu/h)
Burn Rate (kg/h)	1.24	2.73	(lb/h)
Input (kJ/h)	24,512	23,252	(Btu/h)

Test Load Weight (dry kg)	3.30	7.27	dry lb
MC wet (%)	17.36		
MC dry (%)	21.01		
Particulate (g)	5.92		
CO (g)	236		
Test Duration (h)	2.67		

Emissions	Particulate	CO
g/MJ Output	0.12	4.81
g/kg Dry Fuel	1.79	71.54
g/h	2.22	88.51
lb/MM Btu Output	0.28	11.19

Air/Fuel Ratio (A/F)	11.74
----------------------	-------

VERSION:

2.2

12/14/2009

VERSION: 2.2 12/14/2009

Manufacturer: Hearth & Home

Model: Aspen C3

Date: 1/17/2019

Run: 3

Control #: 0135WS044E

Test Duration: 160

Output Category: 3

Appliance Type: Non-Cat

Temp. Units F (F or C)

Weight Units lb (kg or lb)

Wood Moisture (% wet): 17.36
 Load Weight (lb wet): 8.80
 Burn Rate (dry kg/h): 1.24
 Total Particulate Emissions: 5.92 g

Fuel Data

D. Fir
 HHV 19,810 kj/kg
 %C 48.73
 %H 6.97
 %O 43.8
 %ASH 0.5

Averages 0.93 9.46 #DIV/0! 298.73 66.76

Temp. (°F)

Elapsed Time (min)	Fuel Weight Remaining (lb)	Flue Gas Composition (%)			Flue Gas	Room Temp
		CO	CO ₂	O ₂		

0	8.80	0.39	2.51		295.0	68.0
5	8.30	0.74	6.53		264.0	67.0
10	7.80	0.48	11.34		355.0	67.0
15	7.20	0.40	14.26		401.0	67.0
20	6.60	0.45	15.75		432.0	67.0
25	5.90	0.28	16.39		449.0	67.0
30	5.20	0.46	16.07		458.0	67.0
35	4.50	1.09	17.87		487.0	67.0
40	3.70	1.14	17.34		484.0	67.0
45	3.10	0.46	16.96		483.0	67.0
50	2.60	0.17	14.33		435.0	67.0
55	2.20	0.32	12.48		383.0	67.0
60	2.00	0.52	10.81		344.0	68.0
65	1.70	0.44	9.81		309.0	67.0
70	1.50	0.31	9.69		298.0	67.0
75	1.40	0.40	8.92		279.0	67.0
80	1.30	1.11	7.46		261.0	67.0
85	1.20	1.32	7.04		245.0	67.0
90	1.10	1.03	7.61		239.0	67.0
95	1.00	1.06	7.61		236.0	66.0
100	0.90	1.24	7.06		229.0	66.0
105	0.80	1.21	7.05		228.0	67.0
110	0.80	1.24	7.06		223.0	66.0
115	0.70	1.35	6.86		219.0	66.0
120	0.60	1.49	6.43		215.0	67.0
125	0.50	1.58	5.98		207.0	66.0
130	0.50	1.56	5.96		207.0	67.0
135	0.40	1.63	5.36		202.0	66.0
140	0.30	1.31	6.22		199.0	66.0
145	0.30	1.20	6.26		200.0	66.0
150	0.20	1.29	6.22		198.0	66.0
155	0.20	1.38	5.92		199.0	67.0
160	0.00	1.59	4.88		195.0	66.0

ASTM E2780 Wood Heater Run Sheets

Client: Hearth & Home Project Number: 0135WS044E Run Number: 3
 Model: Aspen C3 Tracking Number: 2339 Date: 1/17/19
 Test Crew: B. Davis
 OMNI Equipment ID numbers: _____

Wood Heater Run Notes

Air Control Settings

Primary:

N/A single burn Rate

Secondary: Fixed

Tertiary/Pilot: N/A

Fan: N/A

Preburn Notes

Time	Notes
	<i>Added 10.3 lbs to 2 lbs at coals, burned with door open until 9.5 lbs. Door was closed and pre burn started</i>

Test Notes

Sketch test fuel configuration:

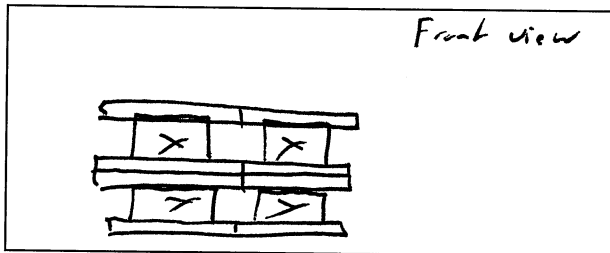

Start up procedures & Timeline:

Bypass: N/A

Fuel loaded by: 55 seconds

Door closed at: 55 seconds

Primary air: N/A single burn Rate

Notes: N/A

Time	Notes
	<i>Filter change was accidentally overlooked</i>

Technician Signature: *B. Davis*

Date: 1/17/19

ASTM E2780 Wood Heater Run Sheets

Client: Hearth & Home Project Number: 0135WS044E Run Number: 3
 Model: Aspen 23 Tracking Number: 2339 Date: 1/17/19
 Test Crew: B. Davis
 OMNI Equipment ID numbers: _____

Wood Heater Fuel Data

Fuel: Douglas fir, untreated and air dried, standard grade or better dimensional lumber

Pre-Burn Fuel					
Calibration:		Cal Value (1) = 12%	Actual Reading	<u>12</u>	
		Cal Value (2) = 22%	Actual Reading	<u>22</u>	
Piece:	Length:	Reading:	Piece:	Length:	Reading:
1	<u>24</u> in	<u>19.2</u>	7	<u>19.1</u> in	<u>18.9</u>
2	<u>24</u> in	<u>23.9</u>	8	<u>24.3</u> in	<u>23.1</u>
3	<u>24</u> in	<u>23.0</u>	9	<u>24.8</u> in	<u>22.8</u>
4	<u>24</u> in	<u>24.5</u>	10	<u>23.7</u> in	<u>24.2</u>
5	_____ in	_____	11	_____ in	_____
6	_____ in	_____	12	_____ in	_____
Total Pre-Burn Fuel Weight: <u>10.3</u>		Pre-Burn Fuel Average Moisture: <u>22.63</u>			
Time (clock): <u>0920</u>		Room Temperature (F): <u>68</u>		Initials: <u>BD</u>	

Test Fuel					
Firebox Volume (ft³): <u>1.39</u>		Test Fuel Piece Length (in): <u>16"</u>			
Load Weight Range (lb): <u>8.8 - 9.73 - 10.7</u>		Total Wet Fuel Load Weight (lb): <u>8.8</u> <u>1.8 - 2.2</u>			
Fuel Type & Amount: 2 x 4: <u>4</u>		4 x 4: <u>N/A</u>			
Weight (with spacers): <u>8.8</u>		Weight (with spacers): _____			
Piece:	Weight (lbs):	Moisture Readings (%DB):			Fuel Type:
1	<u>1.7</u>	<u>20.0</u>	<u>19.0</u>	<u>21.0</u>	<u>2x4</u>
2	<u>1.9</u>	<u>22.4</u>	<u>22.5</u>	<u>22.3</u>	<u>2x4</u>
3	<u>1.7</u>	<u>21.5</u>	<u>21.7</u>	<u>19.1</u>	_____
4	<u>1.6</u>	<u>23.1</u>	<u>19.5</u>	<u>18.9</u>	_____
5	_____	_____	_____	_____	_____
6	_____	_____	_____	_____	_____
7	_____	_____	_____	_____	_____
Spacer Moisture Readings (%DB)					
<u>16.9</u>	<u>21.3</u>	<u>19.8</u>	<u>23.9</u>	_____	_____
<u>19.7</u>	<u>23.9</u>	<u>18.0</u>	<u>22.6</u>	_____	_____
<u>20.6</u>	<u>16.7</u>	<u>21.5</u>	<u>22.2</u>	_____	_____
<u>18.7</u>	<u>24.5</u>	<u>11.8</u>	<u>12.3</u>	_____	_____
Time (clock): <u>0930</u>		Room Temperature (F): <u>68</u>		Initials: <u>BD</u>	

Technician Signature: BD Date: 1/17/19

ASTM E2780 Wood Heater Run Sheets

Client: Hearth & Home Project Number: 0135WS044E Run Number: 3
 Model: Aspen C3 Tracking Number: 2339 Date: 1/17/19
 Test Crew: B. Davis
 OMNI Equipment ID numbers: _____

Wood Heater Supplemental Data

Start Time: 1127 Booth #: E1

Stop Time: 1407

Stack Gas Leak Check:

Initial: good Final: good

Sample Train Leak Check:

A: 0.0 @ 7 "Hg
 B: 0.0 @ 7 "Hg

Calibrations: Span Gas CO₂: 17.05 CO: 4.290 CO ppm: 901

	Pre Test		Post Test	
	Zero	Span	Zero	Span
Time	<u>10:04</u>	<u>10:05</u>	<u>1452</u>	<u>1452</u>
CO ₂	<u>0.06</u>	<u>17.06</u>	<u>0.01</u>	<u>17.11</u>
CO	<u>0.000</u>	<u>4.288</u>	<u>0.000</u>	<u>4.295</u>

Air Velocity (ft/min): Initial: <50 Final: <50
 Scale Audit (lbs): Initial: 10.0 Final: 10.0
 Pitot Tube Leak Test: Initial: good Final: good
 Stack Diameter (in): 6"
 Induced Draft: 0.0
 % Smoke Capture: 100%
 Flue Pipe Cleaned Prior to First Test in Series:
 Date: 1/15/19 Initials: DL

	Initial	Middle	Ending
P _b (in/Hg)	<u>29.56</u>		<u>29.65</u>
RH (%)	<u>31</u>		<u>34</u>
Ambient (°F)	<u>68</u>		<u>66</u>

Tunnel Traverse		
Microtector Reading	dP (in H ₂ O)	T(°F)
	<u>.040</u>	<u>91</u>
	<u>.054</u>	<u>91</u>
	<u>.050</u>	<u>91</u>
	<u>.040</u>	<u>90</u>
	<u>.038</u>	<u>90</u>
	<u>.056</u>	<u>90</u>
	<u>.057</u>	<u>90</u>
	<u>.040</u>	<u>90</u>
Center:		
	<u>.058</u>	<u>91</u>

Background Filter Volume: N/A

Tunnel Static Pressure (in H ₂ O):	
Beginning of Test	End of Test
<u>-.21</u>	<u>-.21</u>

Technician Signature: [Signature]

Date: 1/17/19

Run 4

Wood Heater Test Results - ASTM E2780 / ASTM E2515

Manufacturer: Hearth & Home
 Model: Aspen C3
 Project No.: 0135WS044E
 Tracking No.: 2339
 Run: 4
 Test Date: 01/18/19

Burn Rate	1.25 kg/hr dry
Average Tunnel Temperature	86 degrees Fahrenheit
Average Gas Velocity in Dilution Tunnel - vs	14.16 feet/second
Average Gas Flow Rate in Dilution Tunnel - Qsd	9530.2 dscf/hour
Average Delta p	0.054 inches H2O
Total Time of Test	160 minutes

	AMBIENT	SAMPLE TRAIN 1	SAMPLE TRAIN 2	FIRST HOUR FILTER (TRAIN 1)
Total Sample Volume - Vm	0.000 cubic feet	26.035 cubic feet	26.081 cubic feet	9.705 cubic feet
Average Gas Meter Temperature	69 degrees Fahrenheit	77 degrees Fahrenheit	78 degrees Fahrenheit	77 degrees Fahrenheit
Total Sample Volume (Standard Conditions) - Vmstd	0.000 dscf	25.456 dscf	25.397 dscf	9.489 dscf
Total Particulates - m _p	0 mg	4.8 mg	4.6 mg	2.2 mg
Particulate Concentration (dry-standard) - C _p /C _s	0.000000 grams/dscf	0.00019 grams/dscf	0.00018 grams/dscf	0.00023 grams/dscf
Total Particulate Emissions - E _T	0.00 grams	4.79 grams	4.60 grams	2.21 grams
Particulate Emission Rate	0.00 grams/hour	1.80 grams/hour	1.73 grams/hour	2.21 grams/hour
Emissions Factor		1.44 g/kg	1.38 g/kg	0.87 g/kg
Difference from Average Total Particulate Emissions		0.09 grams	0.09 grams	

Dual Train Comparison Results Are Acceptable

FINAL AVERAGE RESULTS	
Complete Test Run	
Total Particulate Emissions - E _T	4.70 grams
Particulate Emission Rate	1.76 grams/hour
Emissions Factor	1.41 grams/kg
First Hour Emissions	
Total Particulate Emissions - E _T	2.21 grams
Particulate Emission Rate	2.21 grams/hour
Emissions Factor	0.87 grams/kg

QUALITY CHECKS	
Filter Temps < 90 °F	OK
Filter Face Velocity (47 mm)	OK
Dryer Exit Temp < 80F	OK
Leakage Rate	OK
Ambient Temp (55-90°F)	OK
Negative Probe Weight Eval.	OK
Pro-Rate Variation	OK
Stove Surface ΔT	OK

Technician Signature:

Wood Heater Preburn Data - ASTM E2780

Run: **4**
 Manufacturer: Hearth & Home
 Model: Aspen C3
 Tracking No.: 2339
 Project No.: 0135WS044E
 Test Date: 43483
 Beginning Clock Time: 10:56

Coal Bed
 Range **1.8** **2.2**
 (lb): (min) (max)

Technician Signature: 

Elapsed Time (min)	Scale (lb)	Stack Draft (in H ₂ O)	Temperatures (°F)							Stack	Ambient
			FB Top	FB Bottom	FB Back	FB Left	FB Right	Avg. Firebox Surface			
0	9.2	-0.071	644	103	132	281	344	300.8	522	69	
1	9.1	-0.07	653	104	131	283	348	303.8	479	69	
2	9	-0.067	653	106	131	286	352	305.6	454	69	
3	8.9	-0.065	646	107	131	288	355	305.4	432	69	
4	8.8	-0.065	633	109	130	290	358	304	418	69	
5	8.6	-0.063	626	110	130	293	360	303.8	413	69	
6	8.6	-0.064	621	111	130	294	363	303.8	411	69	
7	8.5	-0.065	620	113	130	296	365	304.8	416	69	
8	8.3	-0.066	625	114	129	298	366	306.4	431	69	
9	8.2	-0.067	636	115	129	300	368	309.6	438	69	
10	8.1	-0.067	644	117	129	301	370	312.2	440	70	
11	8	-0.067	655	118	129	303	371	315.2	444	69	
12	7.8	-0.07	669	120	129	304	373	319	456	70	
13	7.7	-0.07	697	121	129	306	374	325.4	476	70	
14	7.6	-0.07	718	122	129	308	375	330.4	478	69	
15	7.4	-0.07	727	124	130	310	376	333.4	472	69	
16	7.3	-0.069	732	125	132	312	377	335.6	470	70	
17	7.2	-0.068	737	126	133	314	377	337.4	467	69	
18	7	-0.068	742	128	135	316	377	339.6	471	70	
19	6.9	-0.071	749	129	137	318	378	342.2	475	70	
20	6.8	-0.072	760	131	138	321	378	345.6	478	70	
21	6.7	-0.071	771	132	140	323	378	348.8	486	69	
22	6.5	-0.071	781	133	142	326	378	352	489	70	
23	6.4	-0.072	788	134	143	328	379	354.4	488	69	
24	6.3	-0.07	794	136	145	331	379	357	488	69	
25	6.2	-0.068	794	137	147	334	379	358.2	481	69	
26	6	-0.069	786	138	149	337	380	358	468	69	
27	5.9	-0.068	773	140	150	340	381	356.8	456	70	
28	5.8	-0.065	758	141	152	343	382	355.2	448	70	
29	5.7	-0.065	745	142	154	346	382	353.8	440	70	
30	5.7	-0.063	734	143	155	349	383	352.8	436	69	
31	5.6	-0.063	723	144	157	352	385	352.2	428	71	
32	5.5	-0.062	712	145	158	355	387	351.4	419	69	
33	5.4	-0.062	699	146	160	358	388	350.2	410	70	
34	5.3	-0.061	687	147	161	361	389	349	401	70	
35	5.2	-0.061	674	148	162	363	391	347.6	395	70	
36	5.1	-0.06	662	149	164	366	392	346.6	388	70	
37	5.1	-0.059	651	150	166	368	393	345.6	382	70	
38	5	-0.056	640	151	168	370	395	344.8	372	69	
39	4.9	-0.056	628	152	169	373	396	343.6	364	70	
40	4.9	-0.055	616	153	171	375	398	342.6	360	70	
41	4.8	-0.055	608	154	173	377	399	342.2	355	70	
42	4.7	-0.054	599	156	174	379	401	341.8	353	70	
43	4.7	-0.054	589	157	175	381	402	340.8	348	69	
44	4.6	-0.053	584	158	177	383	403	341	345	69	
45	4.5	-0.053	578	159	178	385	404	340.8	341	70	
46	4.5	-0.052	571	160	179	387	406	340.6	338	70	
47	4.4	-0.052	566	161	180	388	407	340.4	335	70	
48	4.4	-0.051	561	162	182	389	408	340.4	329	70	
49	4.3	-0.051	555	164	183	391	409	340.4	330	70	
50	4.2	-0.051	551	165	184	393	410	340.6	326	70	
51	4.2	-0.05	546	166	185	394	411	340.4	322	69	
52	4.1	-0.051	542	167	186	395	412	340.4	323	69	
53	4	-0.052	540	168	187	397	413	341	325	69	

Wood Heater Preburn Data - ASTM E2780

Run: **4**

Manufacturer: Hearth & Home
 Model: Aspen C3
 Tracking No.: 2339
 Project No.: 0135WS044E
 Test Date: 43483
 Beginning Clock Time: 10:56

Coal Bed		
Range	1.8	2.2
(lb):	(min)	(max)

Technician Signature: _____

Elapsed Time (min)	Scale (lb)	Stack Draft (in H ₂ O)	Temperatures (°F)							Stack	Ambient
			FB Top	FB Bottom	FB Back	FB Left	FB Right	Avg. Firebox Surface			
54	4	-0.05	539	170	189	398	413	341.8	327	70	
55	3.9	-0.05	537	170	190	399	414	342	327	69	
56	3.8	-0.051	534	172	191	400	415	342.4	324	69	
57	3.8	-0.05	533	173	192	401	415	342.8	322	69	
58	3.7	-0.049	532	174	194	403	416	343.8	323	69	
59	3.7	-0.05	530	175	195	404	417	344.2	324	69	
60	3.6	-0.049	529	176	197	406	419	345.4	323	70	
61	3.6	-0.048	531	176	198	407	419	346.2	323	69	
62	3.5	-0.048	529	177	200	407	421	346.8	322	69	
63	3.4	-0.048	528	178	201	409	422	347.6	318	69	
64	3.4	-0.048	527	179	202	411	423	348.4	320	69	
65	3.3	-0.048	526	180	203	412	424	349	318	69	
66	3.3	-0.048	526	180	204	414	425	349.8	317	70	
67	3.2	-0.049	524	182	205	416	426	350.6	316	69	
68	3.2	-0.049	524	183	207	418	427	351.8	313	69	
69	3.1	-0.048	524	185	208	419	428	352.8	316	69	
70	3.1	-0.048	523	186	209	421	430	353.8	317	69	
71	3	-0.048	523	187	211	423	431	355	313	69	
72	3	-0.048	522	188	212	424	433	355.8	315	69	
73	2.9	-0.048	522	189	213	426	434	356.8	316	69	
74	2.9	-0.047	523	189	214	427	435	357.6	316	69	
75	2.8	-0.048	523	190	216	429	436	358.8	316	69	
76	2.8	-0.049	524	191	217	431	437	360	313	68	
77	2.7	-0.048	525	192	218	433	438	361.2	315	69	
78	2.7	-0.048	526	193	220	434	439	362.4	315	69	
79	2.6	-0.048	527	193	221	436	440	363.4	316	69	
80	2.6	-0.047	526	194	222	437	441	364	315	69	
81	2.5	-0.047	527	195	223	439	442	365.2	311	69	
82	2.5	-0.048	525	195	224	440	443	365.4	310	68	
83	2.4	-0.046	524	196	226	441	444	366.2	308	68	
84	2.4	-0.051	523	197	227	442	444	366.6	306	69	
85	2.3	-0.05	522	198	228	443	444	367	305	68	
86	2.3	-0.05	520	198	229	444	444	367	305	68	
87	2.3	-0.049	516	199	230	444	444	366.6	301	68	
88	2.2	-0.048	513	200	231	445	444	366.6	298	68	
89	2.2	-0.049	507	201	232	446	444	366	296	68	
90	2.2	-0.048	503	201	233	446	444	365.4	293	68	
91	2.1	-0.047	499	202	234	446	443	364.8	289	68	
92	2.1	-0.047	494	203	235	446	442	364	283	69	
93	2.1	-0.045	488	204	236	445	441	362.8	278	68	
94	2	-0.046	482	204	237	444	440	361.4	277	68	
95	2	-0.046	478	205	238	443	439	360.6	273	69	

Wood Heater Test Fuel Data - ASTM E2780

Manufacturer: **Hearth & Home**
 Model: **Aspen C3**
 Tracking No.: **2339**
 Project No.: **0135WS044E**
 Test Date: **1/18/2019**
 Run No.: **4**

Firebox Volume (ft ³):	1.25
Fuel Piece Length (in):	16
2x4 Crib Weight (lb):	8.8
4x4 Crib Weight (lb):	

Total Fuel Weight (Dry Basis, lb):	7.4	
Fuel Density (lb/ft ³ , Dry Basis):	30.21	OK
Loading Density (lb/ft ³ , Wet Basis):	7.04	OK
2x4 Percentage:	N/A	N/A

Coal Bed Range (20-25%): **1.76 - 2.2**

Test Fuel Piece	Weight (lb)	Size	Readings (Dry Basis %)			Dry Weight (lb)
1	1.8	2"x 4"	19.3	18.9	19.1	1.51
2	1.7	2"x 4"	19.2	22.3	20.3	1.41
3	1.8	2"x 4"	22.6	23.5	22.6	1.46
4	1.8	2"x 4"	21.9	19.3	21.4	1.49

Spacer Readings (Dry Basis %)			
9.0	18.9		
12.3	9.9		
7.4	17.5		
10.6			
14.2			
17.9			
18.0			
18.1			
14.8			
18.7			
18.3			
7.0			
18.8			

Technician Signature: 

Wood Heater Lab Data - ASTM E2780 / ASTM E2515

Manufacturer: Hearth & Home Equipment Numbers: 23, 131, 343
 Model: Aspen C3 Tracking
 No.: 2339
 Project No.: 0135WS044E
 Run #: 4
 Date: 1/18/19

TRAIN 1 (First Hour emissions)

Sample Component	Reagent	Filter, Probe or Dish #	Weights		
			Final, mg	Tare, mg	Particulate, mg
B. Front filter catch	Filter	D653	123.2	121.0	2.2
C. Rear filter catch	Filter				0.0
D. Probe catch*	Probe				0.0
E. Filter seals catch*	Seals				0.0

Sub-Total Total Particulate, mg: **2.2**

TRAIN 1 (Post First Hour Change-out)

Sample Component	Reagent	Filter, Probe or Dish #	Weights		
			Final, mg	Tare, mg	Particulate, mg
B. Front filter catch	Filter	D654	121.9	121.5	0.4
C. Rear filter catch	Filter	D655	121.4	121.1	0.3
D. Probe catch*	Probe	27	114274.2	114273.3	0.9
E. Filter seals catch*	Seals	R717	4090.3	4089.3	1.0

Sub-Total Total Particulate, mg: **2.6**

Train 1 Aggregate Total Particulate, mg: **4.8**

TRAIN 2

Sample Component	Reagent	Filter, Probe or Dish #	Weights		
			Final, mg	Tare, mg	Particulate, mg
A. Front filter catch	Filter	D656	124.0	120.8	3.2
B. Rear filter catch	Filter	D657	121.1	121.0	0.1
C. Probe catch*	Probe	28	114750.7	114750.1	0.6
D. Filter seals catch*	Seals	R718	3314.5	3313.8	0.7

Total Particulate, mg: 4.6

AMBIENT

Sample Component	Reagent	Filter # or Probe #	Weights		
			Final, mg	Tare, mg	Particulate, mg
A. Front filter catch*	Filter				0.0

Total Particulate, mg: 0.0

*Particulate catch that results in a negative number, is assumed to be zero for probes and seals, negative numbers for filters are assumed to be part of the seal weight.

Component	Equations:
A. Front filter catch	Final (mg) - Tare (mg) = Particulate, mg
B. Rear filter catch	Final (mg) - Tare (mg) = Particulate, mg
C. Probe catch	Final (mg) - Tare (mg) = Particulate, mg

Technician Signature: 

ABC Laboratories, Inc.

Manufacturer: Hearth & Home
Model: Aspen C3
Date: 01/18/19
Run: 4
Control #: 0135WS044E
Test Duration: 160
Output Category: 3

Technicians: *B. K. [Signature]*

Test Results in Accordance with CSA B415.1-09

	HHV Basis	LHV Basis
Overall Efficiency	75.4%	81.6%
Combustion Efficiency	95.1%	95.1%
Heat Transfer Efficiency	79%	85.8%

Output Rate (kJ/h)	18,501	17,550	(Btu/h)
Burn Rate (kg/h)	1.24	2.73	(lb/h)
Input (kJ/h)	24,542	23,280	(Btu/h)

Test Load Weight (dry kg)	3.30	7.28	dry lb
MC wet (%)	17.26		
MC dry (%)	20.86		
Particulate (g)	4.7		
CO (g)	226		
Test Duration (h)	2.67		

Emissions	Particulate	CO
g/MJ Output	0.10	4.58
g/kg Dry Fuel	1.42	68.44
g/h	1.76	84.79
lb/MM Btu Output	0.22	10.65

Air/Fuel Ratio (A/F)	11.74
-----------------------------	-------

VERSION: 2.2 12/14/2009

VERSION: 2.2 12/14/2009

Manufacturer: Hearth & Home

Model: Aspen C3

Date: 1/18/2019

Run: 4

Control #: 0135WS044E

Test Duration: 160

Output Category: 3

Appliance Type: Non-Cat

Temp. Units F (F or C)

Weight Units lb (kg or lb)

Wood Moisture (% wet): 17.26
 Load Weight (lb wet): 8.80
 Burn Rate (dry kg/h): 1.24
 Total Particulate Emissions: 4.7 g

Fuel Data
 D. Fir
 HHV 19,810 kj/kg
 %C 48.73
 %H 6.97
 %O 43.8
 %ASH 0.5

Averages 0.92 9.46 #DIV/0! 297.36 68.55
 Temp. (°F)

Elapsed Time (min)	Fuel Weight Remaining (lb)	Flue Gas Composition (%)			Flue Gas	Room Temp
		CO	CO ₂	O ₂		
0	8.80	0.21	4.27		308.0	69.0
5	8.30	0.48	5.97		248.0	68.0
10	7.90	0.29	11.47		337.0	68.0
15	7.30	0.31	12.36		375.0	68.0
20	6.70	0.22	12.95		391.0	68.0
25	6.10	0.38	11.65		401.0	67.0
30	5.50	0.78	16.23		428.0	67.0
35	4.70	1.04	16.63		467.0	65.0
40	4.00	1.68	17.40		480.0	65.0
45	3.30	0.70	16.48		474.0	65.0
50	2.80	0.27	14.73		431.0	67.0
55	2.40	0.33	13.32		392.0	68.0
60	2.00	0.33	12.00		363.0	68.0
65	1.70	0.17	11.77		341.0	69.0
70	1.50	0.18	10.00		314.0	69.0
75	1.40	0.63	8.92		285.0	69.0
80	1.30	0.89	8.25		268.0	69.0
85	1.10	0.82	7.93		256.0	69.0
90	1.10	0.98	7.69		245.0	69.0
95	1.00	1.15	7.55		236.0	70.0
100	0.90	1.32	7.31		234.0	69.0
105	0.80	1.32	7.08		230.0	70.0
110	0.70	1.43	6.70		223.0	69.0
115	0.60	1.44	6.67		218.0	70.0
120	0.60	1.41	6.63		217.0	69.0
125	0.50	1.34	6.67		216.0	70.0
130	0.40	1.35	6.47		211.0	69.0
135	0.40	1.35	6.40		210.0	70.0
140	0.30	1.48	6.23		208.0	70.0
145	0.20	1.52	6.20		204.0	69.0
150	0.20	1.55	6.15		203.0	70.0
155	0.10	1.59	6.03		201.0	70.0
160	0.00	1.53	6.03		198.0	70.0

ASTM E2780 Wood Heater Run Sheets

Client: Hearth & Home

Project Number: 0135WS044E

Run Number: 4

Model: Aspen C3

Tracking Number: 2339

Date: 1/18/19

Test Crew: B. Davis

OMNI Equipment ID numbers: _____

Wood Heater Run Notes

Air Control Settings

Primary:

N/A Single burn Rate Appliance

Secondary:

lined

Tertiary/Pilot:

N/A

Fan:

N/A

Preburn Notes

Time	Notes
	<i>Added 10.1 lbs to 2.0 pounds of coals, burned with door open until 9.5 lbs, closed door.</i>

Test Notes

Sketch test fuel configuration:

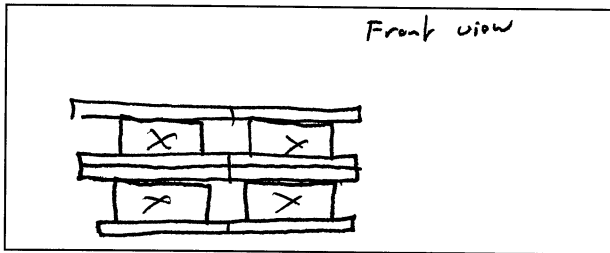

Start up procedures & Timeline:

Bypass:

N/A

Fuel loaded by:

50 seconds

Door closed at:

55 seconds

Primary air:

N/A, Single burn Rate Appliance

Notes:

N/A

Time	Notes
<u>60</u>	<i>Changed front filter in train A</i>

Technician Signature: *B. Davis*

Date: 1/18/19

ASTM E2780 Wood Heater Run Sheets

Client: Hearth & Home Project Number: 0135WS044E Run Number: 4
 Model: Aspen C3 Tracking Number: 2339 Date: 1/18/19
 Test Crew: B. Davis
 OMNI Equipment ID numbers: _____

Wood Heater Fuel Data

Fuel: Douglas fir, untreated and air dried, standard grade or better dimensional lumber

Pre-Burn Fuel					
Calibration:		Cal Value (1) = 12%	Actual Reading	<u>12</u>	
		Cal Value (2) = 22%	Actual Reading	<u>22</u>	
Piece:	Length:	Reading:	Piece:	Length:	Reading:
1	<u>24</u> in	<u>23.0</u>	7	<u>22.3</u> in	<u>19.4</u>
2	<u>24</u> in	<u>18.8</u>	8	<u>22.3</u> in	<u>19.5</u>
3	<u>24</u> in	<u>18.7</u>	9	<u>21.0</u> in	<u>18.5</u>
4	_____ in	_____	10	_____ in	_____
5	_____ in	_____	11	_____ in	_____
6	_____ in	_____	12	_____ in	_____
Total Pre-Burn Fuel Weight: <u>10.1</u>			Pre-Burn Fuel Average Moisture: <u>20.39</u>		
Time (clock): <u>0915</u>		Room Temperature (F): <u>68</u>		Initials: <u>BD</u>	

Test Fuel					
Firebox Volume (ft³): <u>1.39</u>		Test Fuel Piece Length (in): <u>16</u>			
Load Weight Range (lb): <u>8.8 - 9.23 - 10.7</u>		Total Wet Fuel Load Weight (lb): <u>8.8</u> <u>1.8 - 2.2</u>			
Fuel Type & Amount: 2 x 4: <u>4</u>		4 x 4: <u>N/A</u>			
Weight (with spacers): <u>22.0</u> <u>8.8</u>		Weight (with spacers): _____			
Piece:	Weight (lbs):	Moisture Readings (%DB):		Fuel Type:	
1	<u>1.8</u>	<u>19.3</u>	<u>18.9</u>	<u>19.1</u>	<u>2x4</u>
2	<u>1.7</u>	<u>19.2</u>	<u>22.3</u>	<u>20.3</u>	
3	<u>1.8</u>	<u>19.1</u> <u>22.6</u>	<u>19.3</u> <u>23.5</u>	<u>19.1</u> <u>22.6</u>	
4	<u>1.8</u>	<u>21.9</u>	<u>19.3</u>	<u>21.4</u>	
5	_____	_____	_____	_____	
6	_____	_____	_____	_____	
7	_____	_____	_____	_____	
Spacer Moisture Readings (%DB)					
<u>9.0</u>	<u>14.2</u>	<u>14.8</u>	<u>18.8</u>	_____	_____
<u>12.3</u>	<u>17.9</u>	<u>18.7</u>	<u>18.9</u>	_____	_____
<u>7.4</u>	<u>18.0</u>	<u>18.3</u>	<u>9.9</u>	_____	_____
<u>10.6</u>	<u>18.1</u>	<u>7.0</u>	<u>17.5</u>	_____	_____
Time (clock): <u>0920</u>		Room Temperature (F): <u>68</u>		Initials: <u>AD</u>	

Technician Signature: [Signature]

Date: 9/11/18

ASTM E2780 Wood Heater Run Sheets

Client: Hearth & Home Project Number: 0135WS044E Run Number: 4
 Model: Aspen 83 Tracking Number: 2339 Date: 1/18/19
 Test Crew: B. Davis
 OMNI Equipment ID numbers: _____

Wood Heater Supplemental Data

Start Time: 1233 Booth #: E1

Stop Time: 1513

Stack Gas Leak Check:

Initial: good Final: good

Sample Train Leak Check:

A: 00 @ 9 "Hg
 B: 00 @ 7 "Hg

Calibrations: Span Gas CO₂: 17.06 CO: 4.29

	Pre Test		Post Test	
	Zero	Span	Zero	Span
Time	<u>1140</u>	<u>1140</u>	<u>1515</u>	<u>1515</u>
CO ₂	<u>0.00</u>	<u>17.06</u>	<u>0.00</u>	<u>16.96</u>
CO	<u>0.000</u>	<u>4.288</u>	<u>0.001</u>	<u>4.273</u>

Air Velocity (ft/min): Initial: 450 Final: 250

Scale Audit (lbs): Initial: 10.0 Final: 10.0

Pitot Tube Leak Test: Initial: good Final: good

Stack Diameter (in): 6"

Induced Draft: 0.0

% Smoke Capture: 100%

Flue Pipe Cleaned Prior to First Test in Series:

Date: 1/15/19 Initials: BD

	Initial	Middle	Ending
P _b (in/Hg)	<u>30.15</u>		<u>30.03</u>
RH (%)	<u>37</u>		<u>36</u>
Ambient (°F)	<u>69</u>		<u>70</u>

Tunnel Traverse		
Microtector Reading	dP (in H ₂ O)	T(°F)
	<u>.040</u>	<u>83</u>
	<u>.056</u>	<u>83</u>
	<u>.052</u>	<u>83</u>
	<u>.034</u>	<u>83</u>
	<u>.034</u>	<u>83</u>
	<u>.048</u>	<u>82</u>
	<u>.050</u>	<u>82</u>
	<u>.034</u>	<u>82</u>
Center:		
	<u>.054</u>	<u>83</u>

Background Filter Volume: N/A

Tunnel Static Pressure (in H ₂ O):	
Beginning of Test	End of Test
<u>-.21</u>	<u>-.21</u>

Technician Signature: BD

Date: 1/18/19

Section 4

Quality Assurance/Quality Control

QUALITY ASSURANCE/QUALITY CONTROL

OMNI follows the guidelines of ISO/IEC 17025, “General Requirements for the Competence of Testing and Calibration Laboratories,” and the quality assurance/quality control (QA/QC) procedures found in OMNI’s Quality Assurance Manual.

OMNI’s scope of accreditation includes, but is not limited to, the following:

- ANSI (American National Standards Institute) for certification of product to safety standards.
- To perform product safety testing by the International Accreditation Service, Inc. (formerly ICBO ES) under accreditation as a testing laboratory designated TL-130.
- To perform product safety testing as a “Certification Organization” by the Standards Council of Canada (SCC).
- Serving as a testing laboratory for the certification of wood heaters by the U.S. Environmental Protection Agency.

This report is issued within the scope of OMNI’s accreditation. Accreditation certificates are available upon request.

The manufacturing facilities and quality control system for the production of the Aspen C3 at Hearth and Home Technologies were evaluated to determine if sufficient to maintain conformance with OMNI’s requirements for product certification. OMNI has concluded that the manufacturing facilities, processes, and quality control system are adequate to produce the appliance congruous with the standards and model codes to which it was evaluated.

This report shall not be reproduced, except in full, without the written approval of OMNI-Test Laboratories, Inc.

Sample Analysis
Analysis Worksheets
Tared Filter, Probe, and O-Ring Data

ASTM E2780 Wood Heater Run Sheets

Client: Hearth & Home Project Number: 0135WS044E Run Number: 1

Model: Aspen Tracking Number: 2339 Date: 1/15/19

Test Crew: B Davis

OMNI Equipment ID numbers: 637, 592, 283A

ASTM E2515 Lab Sheet

Assembled By:

B Davis

Date/Time in Dessicator:

1/16/19 1610

Weighing #1	Weighing #2	Weighing #3	Weighing #4	Weighing #5
Date/Time: <u>1/23/19 0820</u>	Date/Time: <u>1/23/19 0900</u>	Date/Time: <u>1/23/19 0856</u>		
R/H %: <u>17.6</u>	R/H %: <u>18.4</u>	R/H %: <u>19.7</u>		
Temp: <u>70.5</u>	Temp: <u>70.7</u>	Temp: <u>72.1</u>		
200 mg Audit: <u>200.0</u>	200 mg Audit: <u>200.0</u>	200 mg Audit: <u>200.0</u>		
2 g Audit: <u>2000.2</u>	2 g Audit: <u>2000.2</u>	2 g Audit: <u>2000.2</u>		
100 g Audit: <u>99997.7</u>	100 g Audit: <u>99997.7</u>	100 g Audit: <u>99997.7</u>		
Initials: <u>BD</u>	Initials: <u>BD</u>	Initials: <u>BD</u>		

Train	Element	ID #	Tare (mg)	Weight (mg)	Weight (mg)	Weight (mg)	Weight (mg)	Weight (mg)
A (First Hour)	Front Filter	<u>D644</u>	<u>120.9</u>	<u>126.2</u>	<u>126.3</u>	-		
	Rear Filter							
	Probe							
	O-Ring Set							
A (Remainder)	Front Filter	<u>D645</u>	<u>120.8</u>	<u>121.5</u>	<u>121.6</u>	-		
	Rear Filter	<u>D646</u>	<u>121.5</u>	<u>121.4</u>	<u>121.6</u>	-		
	Probe	<u>17</u>	<u>114561.2</u>	<u>114561.7</u>	<u>114561.9</u>	-		
	O-Ring Set	<u>R711</u>	<u>4104.9</u>	<u>4104.6</u>	<u>4105.0</u>	<u>4104.9</u>	-	
B	Front Filter	<u>D647</u>	<u>121.1</u>	<u>127.0</u>	<u>127.1</u>	-		
	Rear Filter	<u>D648</u>	<u>120.6</u>	<u>120.5</u>	<u>120.7</u>	-		
	Probe	<u>18</u>	<u>114401.5</u>	<u>114402.5</u>	<u>114402.6</u>	-		
	O-Ring Set	<u>R712</u>	<u>3413.6</u>	<u>3413.8</u>	<u>3414.2</u>	<u>3414.0</u>	-	
BG	Filter			<u>~</u>				

Technician Signature: B Davis

Date: 1/25/19

ASTM E2780 Wood Heater Run Sheets

Client: Hearth & Home Project Number: 0135WS044E Run Number: 3
 Model: Aspen Tracking Number: 2339 Date: 1/17/19
 Test Crew: B. Davis
 OMNI Equipment ID numbers: 637, 592, 2824

ASTM E2515 Lab Sheet

Assembled By:

B Davis

Date/Time in Dessicator:

1630 1/17/19

Weighing #1	Weighing #2	Weighing #3	Weighing #4	Weighing #5
Date/Time: <u>1/24/19 0820</u>	Date/Time: <u>1/23/19 0820</u>	Date/Time: <u>1/24/19 0856</u>		
R/H %: <u>17.6</u>	R/H %: <u>18.4</u>	R/H %: <u>19.7</u>		
Temp: <u>70.5</u>	Temp: <u>70.7</u>	Temp: <u>72.1</u>		
200 mg Audit: <u>200.0</u>	200 mg Audit: <u>200.0</u>	200 mg Audit: <u>200.0</u>		
2 g Audit: <u>2000.2</u>	2 g Audit: <u>2000.2</u>	2 g Audit: <u>2000.2</u>		
100 g Audit: <u>99997.7</u>	100 g Audit: <u>99997.7</u>	100 g Audit: <u>99997.7</u>		
Initials: <u>BD</u>	Initials: <u>BD</u>	Initials: <u>BD</u>		

Train	Element	ID #	Tare (mg)	Weight (mg)	Weight (mg)	Weight (mg)	Weight (mg)	Weight (mg)
A (First Hour)	Front Filter	D650	122.0	125.7	125.8	✓		
	Rear Filter							
	Probe							
	O-Ring Set							
A (Remainder)	Front Filter	D 326	111.5	Not used				
	Rear Filter	D 327	112.5	112.7	112.9	✓		
	Probe	24	114126.5	114126.7	114127.0	114127.1	✓	
	O-Ring Set	R713	3391.9	3393.0	3393.2	✓		
B	Front Filter	D529	112.6	116.6	116.8	✓		
	Rear Filter	D530	112.8	112.7	112.8	✓		
	Probe	25	114298.7	114298.7	114299.0	114299.1	✓	
	O-Ring Set	R714	3534.1	3534.9	3535.1	✓		
BG	Filter							

Technician Signature: B Davis

Date: 1/25/19

ASTM E2780 Wood Heater Run Sheets

Client: Hearth & Home Project Number: 0135WS044E Run Number: 4

Model: Aspen Tracking Number: 2339 Date: 1/18/19

Test Crew: B. Davis

OMNI Equipment ID numbers: _____

ASTM E2515 Lab Sheet

Assembled By:

B. Davis

Date/Time in Dessicator:

1/18/19 15:25

Weighing #1	Weighing #2	Weighing #3	Weighing #4	Weighing #5
Date/Time: <u>1/18/19</u>	Date/Time: <u>1/23/19 0900</u>	Date/Time: <u>1/24/19 0856</u>	Date/Time:	Date/Time:
R/H %: <u>17.6</u>	R/H %: <u>18.4</u>	R/H %: <u>19.7</u>	R/H %:	R/H %:
Temp: <u>70.5</u>	Temp: <u>70.7</u>	Temp: <u>72.1</u>	Temp:	Temp:
200 mg Audit: <u>200.0</u>	200 mg Audit: <u>200.0</u>	200 mg Audit: <u>200.0</u>	200 mg Audit:	200 mg Audit:
2 g Audit: <u>2000.2</u>	2 g Audit: <u>2000.2</u>	2 g Audit: <u>2000.2</u>	2 g Audit:	2 g Audit:
100 g Audit: <u>99997.7</u>	100 g Audit: <u>99997.7</u>	100 g Audit: <u>99997.7</u>	100 g Audit:	100 g Audit:
Initials: <u>BD</u>	Initials: <u>BD</u>	Initials: <u>BD</u>	Initials:	Initials:

Train	Element	ID #	Tare (mg)	Weight (mg)	Weight (mg)	Weight (mg)	Weight (mg)	Weight (mg)
A (First Hour)	Front Filter	D653	121.0	123.3	123.2			
	Rear Filter							
	Probe							
	O-Ring Set							
A (Remainder)	Front Filter	D654	121.5	121.7	121.9			
	Rear Filter	D655	121.1	121.3	121.4			
	Probe	27	114273.3	114274.2	114274.2			
	O-Ring Set	R717	4089.3	4090.1	4090.5	4090.3		
B	Front Filter	D656	120.8	123.9	124.0			
	Rear Filter	D657	121.0	121.1	121.1			
	Probe	28	114750.1	114750.7	114751.2	114750.5	114750.7	
	O-Ring Set	R718	3313.8	3314.4	3314.7	3314.5		
BG	Filter							

Technician Signature: B. Davis

Date: 1/25/19

Tare Sheet: (check one)

Probes _____

47mm Filters

100mm Filters _____

O-Ring Pair _____

Prepared By: B. DAVIS

Balance ID #: Omni-00637

Thermohyrometer ID #: Omni-00592

Audit Weight ID #/Mass: 00283A

1 200 mg

Placed in Dessicator:	Date: <u>1/17/19</u>	Date: <u>1/18/19</u>	Date: _____	Date: _____	Date Used	Project Number	Run No.
Date: <u>1/14/19</u>	Time: <u>12:15</u>	Time: <u>08:11</u>	Time: _____	Time: _____			
Time: <u>08:30</u>	RH %: <u>11.9</u>	RH %: <u>10.8</u>	RH %: _____	RH %: _____			
	T (°F): <u>76.7</u>	T (°F): <u>70.1</u>	T (°F): _____	T (°F): _____			
ID #	Audit: <u>199.7</u>	Audit: <u>200.0</u>	Audit: _____	Audit: _____			
D653	120.9	121.0	-		1/18/19	013546044E	4
D654	121.6	121.5	-				
D655	121.2	121.1	-				
D656	120.7	120.8	-				
D657	121.2	121.0	-				
D658	120.8	120.8	-				
D659	^{120.8} 120.8	120.7	-				
D660	120.6	120.4	-				
D661	120.6	120.6	-				
D662	121.5	121.4	-				
D663	120.4	120.6	-				
D664	121.5	121.5	-				
D665	120.2	120.1	-				
D666	121.0	120.8	-				
D667	120.8	120.7	-				
D668	120.8	120.8	-				
D669	120.1	120.3	-				
D670	120.9	120.9	-				
D671	120.8	120.8	-				
D672	122.1	122.1	-				
Initials: <u>BD</u>	Initials: <u>BR</u>	Initials: _____	Initials: _____				

Final Technician Signature: B. Davis
 Control No. P-SFDP-0002.xls, Effective date: 2/1/2017

Date: 2/23/19

Evaluator signature: K. J. Mung

Tare Sheet: (check one)

Probes

47mm Filters

100mm Filters

O-Ring Pair

Prepared By: A. Wroble

Balance ID #: 637

Thermohyrometer ID #: 5a2

Audit Weight ID #/Mass: 287 A 1 102g

Placed in Dessicator: Date: <u>1/8/19</u> Time: <u>12:00</u>	Date: <u>1/11/19</u> Time: <u>230</u> RH %: <u>9.4</u> T (°F): <u>71.7</u> Audit: <u>99997.8</u>	Date: <u>1/14/19</u> Time: <u>0910</u> RH %: <u>12.1</u> T (°F): <u>70.4</u> Audit: <u>99997.8</u>	Date: <u>1/15/19</u> Time: <u>0930</u> RH %: <u>13.5</u> T (°F): <u>70.6</u> Audit: <u>99997.8</u>	Date: <u>1/16/19</u> Time: <u>1025</u> RH %: <u>14.4</u> T (°F): <u>71.0</u> Audit: <u>99997.8</u>	Date Used	Project Number	Run No.
13	114321.9	114322.1	✓				
15	114341.4	114341.7	✓				
16	114267.1	114266.7	114267.0	114266.7	Not used		
17	114561.3	114561.0	114561.2		1/17/19	013545044E	1
18	114401.8	114401.4	114401.5	✓	↓	↓	↓
20	114253.0	114252.9	✓				
21	114392.6	114392.1	114392.6	114392.1	Not used		
22	114344.6	114344.4	✓				
23	114676.8	114076.4	114076.7	114076.3	Not used		
24	114127.0	114126.3	114126.7	114126.5	1/17/19	013545044E	3
25	114298.9	114298.5	114298.7	✓	↓	↓	↓
27	114273.6	114273.3	✓		1/18/19	↓	4
28	114750.1	114750.1	✓		↓	↓	↓
29	114277.6	114277.5	✓				
30	114327.8	114328.0	114328.2	✓			

Initials: AW Initials: BR Initials: BR Initials: BR

Final Technician Signature: [Signature]
Control No. P-SFDP-0002.xls, Effective date: 2/1/2017

Date: 1/22/19

Evaluator signature: [Signature]

Tare Sheet: (check one)

Probes _____

47mm Filters

100mm Filters _____

O-Ring Pair _____

Prepared By: B DAVIS

Balance ID #: OMMI-00637

Thermohyrometer ID #: OMMI-00592

Audit Weight ID #/Mass: OMMI-00287-A / 200.0

Placed in Dessicator: Date: <u>12/13/18</u> Time: <u>10:20</u>	Date: <u>12/14/18</u> Time: <u>10:40</u> RH %: <u>10.7</u> T (°F): <u>67.4</u> Audit: <u>200.0</u>	Date: <u>12/17/18</u> Time: <u>12:20</u> RH %: <u>13.2</u> T (°F): <u>66.9</u> Audit: <u>200.0</u>	Date: _____ Time: _____ RH %: _____ T (°F): _____ Audit: _____	Date: _____ Time: _____ RH %: _____ T (°F): _____ Audit: _____	Date Used	Project Number	Run No.
	ID #						
D633	120.1	120.2	-				
D634	122.0	122.1	-				
D635	121.3	121.1	-				
D636	121.0	121.0	-				
D637	121.3	121.4	-				
D638	121.2	121.3	-				
D639	120.7	120.6	-				
D640	121.0	121.1	-				
D641	121.1	121.1	-				
D642	121.6	121.5	-				
D643	121.5	121.5	-				
D644	120.8	120.9	-		1/15/19	0135WS044E	1
D645	120.7	120.8	-				
D646	121.6	121.5	-				
D647	121.2	121.1	-				
D648	120.6	120.6	-				
D649	121.3	121.2	-				
D650	122.0	122.0	-		1/17/19	0135WS044E	3
D651	121.2	121.0	-				
D652	120.5	120.4	-				
Initials: <u>BD</u>	Initials: <u>DL</u>	Initials: _____	Initials: _____				

Final Technician Signature: BD

Date: 12/17/18

Evaluator signature: [Signature]

Tare Sheet: (check one)

Probes _____

47mm Filters _____

100mm Filters _____

O-Ring Pair

Prepared By: A. Urawitz

Balance ID #: 637

Thermohyrometer ID #: 592

Audit Weight ID #/Mass: 283A 1 2g

Placed in Dessicator: Date: <u>1/18/19</u> Time: <u>1200</u>	Date: <u>1/11/16</u>	Date: <u>1/14/19</u>	Date: <u>1/15/19</u>	Date: <u>1/16/19</u>	Date Used	Project Number	Run No.
	Time: <u>230</u>	Time: <u>0900</u>	Time: <u>0930</u>	Time: <u>10:25</u>			
RH %: <u>3.1</u>	RH %: <u>12.8</u>	RH %: <u>13.8</u>	RH %: <u>14.4</u>				
T (°F): <u>72.1</u>	T (°F): <u>70.5</u>	T (°F): <u>70.6</u>	T (°F): <u>71.0</u>				
Audit: <u>2000.1</u>	Audit: <u>2000.2</u>	Audit: <u>2000.2</u>	Audit: <u>2000.2</u>	Audit: <u>2000.2</u>			
R711	4105.1	4104.9			1/15/19	0135WS044E	1
R712	3414.3	3413.8	3413.6		↓		↓
R713	3392.9	3392.0	3391.9		1/17/19		3
R714	3514.7	3514.3	3514.1		↓		↓
R715	3322.1	3321.5	3321.4				
R716	3552.8	3552.2	3552.3				
R717	4092.2	4089.5	4089.3		1/15/19	0135WS044E	4
R718	3314.5	3314.1	3313.7	3313.8	↓		↓
R719	3589.6	3588.9	3588.7				
R720	3325.5	3324.8	3324.7				
R721	3345.0	3344.2	3344.2				
R722	3336.0	3335.3	3335.3				
R723	3356.9	3356.4	3356.2				
R724	4097.1	4096.2	4095.8	4095.7			
R725	3357.4	3356.7	3356.5				
Initials: <u>AM</u>	Initials: <u>AM</u>	Initials: <u>AM</u>	Initials: <u>AM</u>				

Final Technician Signature: [Signature]

Date: 1/15/19

Evaluator signature: [Signature]

Control No. P-SFDP-0002.xls, Effective date: 2/1/2017

Calibrations

Methods EPA 28R, ASTM E2515, ASTM E2780

ID #	Lab Name/Purpose	Log Name	Attachment Type
637	Scale-Analytical Balance	Mettler Analytical Balance	Calibration Certificate
283A	Audit Weights	21-Piece weight set	Calibration Certificate
132	10 lb Weight	Weight Standard, 10 lb.	Calibration Certificate
185	Platform Scale	Weigh-Tronix Platform Scale	Calibration Certificate
209	Barometer	Barometer – Princo	Manual Cover
296-T58	Tape Measure	Stanley Tape Measure	Calibration Log
335	Sample Box / Dry Gas Meter	Apex Automated Emissions Sampling Box	Calibration Log
336	Sample Box / Dry Gas Meter	Apex Automated Emissions Sampling Box	Calibration Log
592	Thermohygrometer	Omega Digital Thermohygrometer	Calibration Log
410	Microtector	Dwyer Microtector	Calibration Certificate
594	Combustion Gas Analyzer	Infrared Gas Analyzer	Manual, See Test Run Notes
443	Stopwatch	Robotic Stopwatch SC-606W	Calibration Log
431	Moisture Meter Calibrator	Delmhorst Moisture Content Calibrator	Calibration Log
265	Vaneometer	Dwyer Vaneometer	Manual

Certificate of Calibration

Certificate Number: **692254**



JJ Calibrations, Inc.

7007 SE Lake Rd
Portland, OR 97267-2105
Phone 503.786.3005
FAX 503.786.2994

Omni-Test Laboratories
13327 NE Airport Way
Portland, OR 97230

OnSite

PO: **181203**

Order Date: **01/11/2019**

Authorized By: **N/A**



Calibrated on: **01/11/2019**

*Recommended Due: **07/11/2019**

Environment: **19 °C 43 % RH**

* As Received: **Within Tolerance**

* As Returned: **Within Tolerance**

Action Taken: **Calibrated**

Technician: **123**

Property #: **OMNI-00637**

User: **N/A**

Department: **N/A**

Make: **Mettler Toledo**

Model: **MS104TS/00**

Serial #: **B729400181**

Description: **Analytical Scale, 120g**

Procedure: **DCN 500887**

Accuracy: **±0.0005g**

Remarks: * Many factors may cause the unit to drift out of calibration before the recommended due date. Any reported error is the absolute value between the reference and the unit. Uncertainties include the effects of the unit.

Standards Used

Std ID	Manufacturer	Model	Nomenclature	Due Date	Trace ID
256A	Rice Lake	W0133K	Mass Set,	05/30/2019	660578

Measurement Data

Parameter	Measurement Description	Range	Unit	Reference	Min	Max	*Error	UUT	Uncertainty
Before/After Force									Accredited = U
			g	10.00000	9.9995	10.0005	0.0000	10.0000 g	5.7E-04 U
			g	30.00000	29.9995	30.0005	0.0000	30.0000 g	5.7E-04 U
			g	60.00000	59.9995	60.0005	0.0002	59.9998 g	5.7E-04 U
			g	90.00000	89.9995	90.0005	0.0001	89.9999 g	5.7E-04 U
			g	120.00000	119.9995	120.0005	0.0002	119.9998 g	5.7E-04 U

JJ Calibrations, Inc. certifies that this instrument has been calibrated in accordance with the JJ Calibrations Quality Assurance Manual with the stated procedure using standards that are traceable to the National Institute of Standards and Technology (NIST), or other National Measurement Institutes (NMI's), or by using natural physical constants, intrinsic standards or ratio calibration techniques. The quality system and this certificate are in compliance with ANSI/NCCL Z540-1-1994, ISO/IEC 17025-2005, ISO 10012-1, the ISO 9000 family and QS 9000. The expanded uncertainties of measurements for this calibration are based upon 95% (2 sigma) confidence limits. Unless otherwise stated, a test accuracy ratio (TAR) of 4:1, if achievable, is maintained. The results reported herein apply only to the calibration of the item described above. This report may not be reproduced, except in full, without prior written consent of JJ Calibrations, Inc. JJ Calibrations, Inc. quality system has been assessed and accredited to ISO/IEC 17025:2005.

Reviewer

3 Issued 01/14/2019 Rev # 15

Inspector

Certificate of Calibration

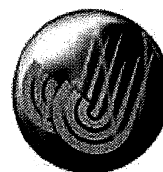

JJ Calibrations, Inc.

7007 SE Lake Rd
Portland, OR 97267-2105
Phone 503.786.3005
FAX 503.786.2994

Certificate Number: **685888**

Omni-Test Laboratories
13327 NE Airport Way
Portland, OR 97230

PO: **180188**
Order Date: **10/09/2018**
Authorized By: **N/A**



Calibrated on: **10/26/2018**
*Recommended Due: **10/26/2023**
Environment: **20 °C 57 % RH**
* As Received: **Within Tolerance**
* As Returned: **Within Tolerance**
Action Taken: **Calibrated**
Technician: **139**

Property #: **OMNI-00283A**
User: **N/A**
Department: **N/A**
Make: **Troemner Inc**
Model: **1mg-100g (Class F)**
Serial #: **47883**
Description: **Mass Set, 21pc**
Procedure: **DCN 500901**
Accuracy: **Class F**

Remarks: * Many factors may cause the unit to drift out of calibration before the recommended due date. Any reported error is the absolute value between the reference and the unit. Uncertainties include the effects of the unit.

This set meets Class F specifications.
Received and returned eight (8) masses in a black case secured by a rubber band.

Standards Used

Std ID	Manufacturer	Model	Nomenclature	Due Date	Trace ID
723A	Rice Lake	1mg-200g (Class 0)	Mass Set,	03/23/2019	668240
800A	Sartorius	MSA225W100DI	Analytical Balance	12/11/2018	663857

Measurement Data

Parameter	Measurement Description	Range Unit	Reference	Min	Max	*Error	UUT	Uncertainty
Before/After								Accredited = ✓
Mass								
Dot	200 mg	200.00030	199.4603	200.5403	0.0500	200.0503 mg	6.2E-01	✓
	1 g	1.0000880	0.9991088	1.0009088	0.0000000	1.000088 g	1E-03	✓
	2 g	2.00001470	1.9989147	2.0011147	0.0003250	2.0003397 g	1.3E-03	✓
	5 g	5.00000840	4.9985084	5.0015084	0.0000400	4.9999684 g	1.7E-03	✓
	10 g	10.0000100	9.998010	10.002010	0.000245	9.999765 g	2.3E-03	✓
Dot	20 g	20.0000140	19.996014	20.004014	0.000990	20.001004 g	4.6E-03	✓
	50 g	49.9999660	49.989966	50.009966	0.000595	49.999371 g	1.1E-02	✓
	100 g	100.000000	99.98000	100.02000	0.00194	99.99806 g	2.3E-02	✓

JJ Calibrations, Inc. certifies that this instrument has been calibrated in accordance with the JJ Calibrations Quality Assurance Manual with the stated procedure using standards that are traceable to the National Institute of Standards and Technology (NIST), or other National Measurement Institutes (NMI's), or by using natural physical constants, intrinsic standards or ratio calibration techniques. The quality system and this certificate are in compliance with ANSI/NCCL Z540-1-1994, ISO/IEC 17025-2005, ISO 10012-1, the ISO 9000 family and QS 9000. The expanded uncertainties of measurements for this calibration are based upon 95% (2 sigma) confidence limits. Unless otherwise stated, a test accuracy ratio (TAR) of 4:1, if achievable, is maintained. The results reported herein apply only to the calibration of the item described above. This report may not be reproduced, except in full, without prior written consent of JJ Calibrations, Inc.
JJ Calibrations, Inc. quality system has been assessed and accredited to ISO/IEC 17025:2005.

Reviewer

3 Issued 10/29/2018 Rev # 15

Inspector

SCALE WEIGHT CALIBRATION DATA SHEET

Weight to be calibrated: 10 pounds

ID Number: OMNI-00132

Standard Calibration Weight: 10 pounds

ID Number: OMNI-00255

Scale Used: MTW-150K

ID Number: OMNI-00353

Date: 2/23/2018

By: B. Davis

Standard Weight (A) (Lb.)	Weight Verified (B) (Lb.)	Difference (A - B)	% Error
10.0	10.0	0.0	0

*Acceptable tolerance is 1%.

This calibration is traceable to NIST using calibrated standard weights.

Technician signature:  Date: 2/23/18



QUALITY CONTROL SERVICES

LABORATORY EQUIPMENT • SALES • SERVICE • CALIBRATION • REPAIRS
2340 SE 11TH Ave. Portland, Oregon 97214 • Box 14831 Portland, Oregon 97293
(503) 236-2712 • FAX (503) 235-2535 • www.qc-services.com



OMNI-Test Laboratories, Inc.
13327 NE Airport Way
Portland, OR 97230

Report Number: OMNE0321676181002

A2LA ACCREDITED CERTIFICATE OF CALIBRATION WITH DATA

INSTRUMENT INFORMATION

Item	Make	Model	Serial Number	Customer ID	Location
Scale	Weigh-Tronix	WI-127 1000x0.1lb	21676	185	Lab
Units	Readability	SOP	Cal Date	Last Cal Date	Cal Due Date
lbs	0.1	QC033	10/2/18	10/4/17	10/2019

FUNCTIONAL CHECKS

SHIFT TEST		LINEARITY		REPEATABILITY		ENVIRONMENTAL CONDITIONS		
Test Wt:	Tol:	Test Wt:	Tol:	Test Wt:	Tol:	<input type="checkbox"/>	<input checked="" type="checkbox"/>	<input type="checkbox"/>
500	0.5	HB44	HB44	200	0.2	Good	Fair	Poor
As-Found:		As-Found:		As-Found:		Temperature: 20.2°C		
Pass: <input checked="" type="checkbox"/>	Fail: <input type="checkbox"/>	Pass: <input checked="" type="checkbox"/>	Fail: <input type="checkbox"/>	Pass: <input checked="" type="checkbox"/>	Fail: <input type="checkbox"/>			
As-Left:		As-Left:		As-Left:				
Pass: <input checked="" type="checkbox"/>	Fail: <input type="checkbox"/>	Pass: <input checked="" type="checkbox"/>	Fail: <input type="checkbox"/>	Pass: <input checked="" type="checkbox"/>	Fail: <input type="checkbox"/>			

CALIBRATION DATA

Standard	As-Found	As-Left	Expanded Uncertainty
1000	999.8	999.8	0.12
700	699.8	699.8	0.12
500	499.9	499.9	0.08
200	200.0	200.0	0.08
100	100.0	100.0	0.05
50	50.0	50.0	0.05

CALIBRATION STANDARDS

Item	Make	Model	Serial Number	Cal Date	Cal Due Date	NIST ID
Avoirdupois Cast W	Rice Lake	25 and 50lb	PWO990-CA	11/24/17	11/2019	20172265

Permanent Information Concerning this Equipment:

Comments/Information Concerning this Calibration

10/2/2018 - Relative Humidity = 61.0 %

Report prepared/reviewed by: 

Date:

10-2-18

Technician: D. Oudeans

Signature: 

THIS CERTIFICATE SHALL NOT BE REPRODUCED, EXCEPT IN FULL, WITHOUT THE APPROVAL OF QUALITY CONTROL SERVICES, INC.

The uncertainty is calculated according to the ISO Guide to the Expression of Uncertainty in Measurement and includes the uncertainty of standards used combined with the observed standard deviation of the unit under test. The uncertainty is expanded with a k factor of 2 for an approximate 95% level of confidence. Instruments listed above were calibrated using standards traceable to the National Institute of Standards and Technology (NIST). Calibration data reflect results at the time and location of calibration. Calibration data should be reviewed to insure that the instrument is performing to its required accuracy.

OMNI 00209

Instruction Booklet

for use with

PRINCO

Fortin type mercurial

Barometers

Manufactured by

PRINCO INSTRUMENTS, INC.

1020 Industrial Blvd.

Southampton, Pa. 18966-4095

U.S.A.

Phone: 215 355-1500

Fax: 215 355-7766



453
National
Weather
Service
Type

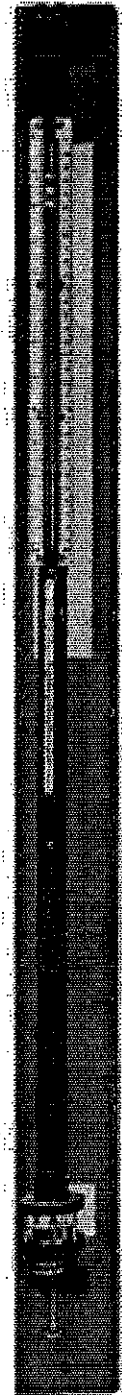

463
NOVA™
Economy
Model

ZRE

NDIR/O₂



USER'S

MANUAL



1312 West Grove Avenue
Orange, CA 92865-4134
Phone: 714-974-5560 Fax: 714-921-2531
www.gasanalyzers.com

Tape Measure Calibration Log

Place the calibrated 12" ruler under the tape measure and verify that each 1/2" (i.e. 1.5", 2", 2.5") between 0 and 36" is within 1/8".

Calibrated using OMNI-00281

Tape Measure Number	Description	Cal Dates				Technician Initials			
OMNI-00296-T55	Dewalt 16' Tape Measure	12/12/16				BR			
OMNI-00296-T56	Dewalt 25' Tape Measure	12/12/16				BR			
OMNI-00296-T59	Dewalt 25' Tape Measures	12/12/16				BR			
OMNI-00296-T58	Dewalt 25' Tape measure	3/9/17	4/3/18			BR	BR		
OMNI-00296-T40	Stanley FatMax Tape measure 16'	11/17/17				NIS			
OMNI-00296-T31	Stanley Powerlock Tape Measure	11/22/17				NIS			
OMNI-00296-T59	DeWalt 25' tape Measure	12/06/17				NIS			
OMNI-00296-T54	DeWalt 25' tape Measure	12/06/17				NIS			
OMNI-00296-T56	DeWalt 25' tape Measure	12/06/17				NIS			
OMNI-00296-T55	DeWalt 25' tape Measure	12/06/17	4/3/18			NIS	AR		

Thermal Metering System Calibration Y Factor

Manufacturer: APEX
 Model: XC-60-EP
 Serial Number: 606001
 OMNI Tracking No.: OMNI-00335
 Calibrated Orifice:

Average Gas Meter y Factor
0.986

Orifice Meter dH@
N/A

Calibration Date: 07/17/18
 Calibrated by: B. Davis
 Calibration Frequency: Six months
 Next Calibration Due: 1/17/2019
 Instrument Range: 1.000 cfm
 Standard Temp.: 68 oF
 Standard Press.: 29.92 "Hg
 Barometric Press., Pb: 30.12 "Hg
 Signature/Date: *B. Davis* 7/18/2018

Previous Calibration Comparison

Date	<u>1/17/2018</u>	Acceptable Deviation (5%)	Deviation
y Factor	<u>0.977</u>	0.04885	0.009
Acceptance	Acceptable		

Current Calibration

Acceptable y Deviation	0.020
Maximum y Deviation	0.008
Acceptable dH@ Deviation	N/A
Maximum dH@ Deviation	N/A
Acceptance	Acceptable

Reference Standard *

Standard	Model	Standard Test Meter
Calibrator	S/N	<u>OMNI-00001</u>
	Calib. Date	<u>30-Oct-17</u>
	Calib. Value	<u>0.9977</u> y factor (ref)

Calibration Parameters	Run 1	Run 2	Run 3
Reference Meter Pressure ("H2O), Pr	<u>0.00</u>	<u>0.00</u>	<u>0.00</u>
DGM Pressure ("H2O), Pd	<u>2.00</u>	<u>1.38</u>	<u>1.00</u>
Initial Reference Meter	<u>609.1</u>	<u>615.5</u>	<u>620.8</u>
Final Reference Meter	<u>615.4</u>	<u>620.7</u>	<u>626.7</u>
Initial DGM	<u>0</u>	<u>0</u>	<u>0</u>
Final DGM	<u>6.292</u>	<u>5.245</u>	<u>5.995</u>
Temp. Ref. Meter (°F), Tr	<u>92.0</u>	<u>93.0</u>	<u>91.0</u>
Temperature DGM (°F), Td	<u>92.0</u>	<u>93.0</u>	<u>91.0</u>
Time (min)			
Net Volume Ref. Meter, Vr	6.300	5.200	5.900
Net Volume DGM, Vd	6.292	5.245	5.995
Gas Meter y Factor =	0.994	0.986	0.979
Gas Meter y Factor Deviation (from avg.)	0.008	0.001	0.007
Orifice dH@	N/A	N/A	N/A
Orifice dH@ Deviation (from avg.)	N/A	N/A	N/A

where:

1. Deviation = |Average value for all runs - current run value|
- ** 2. $y = [Vr \times (y \text{ factor (ref)}) \times (Pb + (Pr / 13.6)) \times (Td + 460)] / [Vd \times (Pb + (Pd / 13.6)) \times (Tr + 460)]$
- ** 3. $dH@ = 0.0317 \times Pd / (Pb (Td + 460)) \times [(Tr + 460) \times \text{time}] / Vr]^2$

* Reference calibration is traceable to NIST through NIST Test # 40674, Kimble ASTM E1272, or NIST traceable laboratory

** Equations come from EPA Method 5

The uncertainty of measurement is $\pm 0.14 \text{ ft}^3/\text{min}$. This is based on the reference standard having a TAR (Test Accuracy Ratio) of at least 4:1.

DIFFERENTIAL PRESSURE GAUGE CALIBRATION DATA SHEET

Instrument to be calibrated: Pressure Transducer

Maximum Range: 0-2" WC ID Number: OMNI-00335

Calibration Instrument: Digital Manometer ID Number: OMNI-00395

Date: 7/18/2018 By: B. Davis

This form is to be used only in conjunction with Standard Procedure C-SPC.

Range of Calibration Point ("WC)	Digital Manometer Input ("WC)	Pressure Gauge Response ("WC)	Difference (Input - Response)	% Error of Full Span*
0-20% Max. Range 0 - 0.4	0.183	0.183	0.0	0.0
20-40% Max. Range 0.4 - 0.8	0.705	0.704	0.001	0.05
40-60% Max. Range 0.8 - 1.2	1.019	1.016	0.003	0.15
60-80% Max. Range 1.2 - 1.6	1.394	1.391	0.003	0.15
80-100% Max. Range 1.6 - 2.0	1.980	1.978	0.002	0.10

*Acceptable tolerance is 4%.

The uncertainty of measurement is ± 0.4 " WC. This is based on the reference standard having a TAR (Test Accuracy Ratio) of at least 4:1.

Technician signature:  Date: 7/18/18



Reviewed by:  Date: 7/20/18

Temperature Calibration EPA Method 28R, ASTM 2515								
BOOTH:		TEMPERATURE MONITOR TYPE:				EQUIPMENT NUMBER:		
Mobile		National Instruments Logger				00335, 00336		
REFERENCE METER EQUIPMENT NUMBER: 00373				Calibration Due Date: 8/02/17				
CALIBRATION PERFORMED BY:			DATE:		AMBIENT TEMPERATURE:		BAROMETRIC PRESSURE:	
B. Davis			7/17/18		76		30.12	
Input Temperature (F)	Ambient	Meter A					Tunnel	FB Interior
			Meter B	Filter A	Filter B			
0	0	1	1	1	1	0	0	
100	100	101	101	100	100	100	100	
300	300	300	300	300	300	300	300	
500	500	501	500	500	500	500	500	
700	700	700	700	700	700	700	700	
1000	1000	1001	1000	1000	1000	1000	1000	

Input (F)	FB Top	FB Bottom	FB Back	FB Left	FB Right	Imp A	Imp B	Cat	Stack
0	0	0	0	0	0	1	1	1	0
100	100	100	100	100	100	101	101	101	100
300	300	300	300	300	300	300	300	300	300
500	500	500	500	500	500	500	500	500	500
700	700	700	700	700	700	700	700	700	700
1000	1000	1000	1000	1000	1000	1000	1000	1000	1000

1500
2000

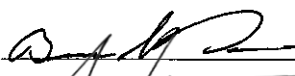
1500
2000

Technician signature:  Date: 7/17/18
 Reviewed By:  Date: 7/20/18

Thermal Metering System Calibration Y Factor

Manufacturer: APEX
 Model: XC-60-EP
 Serial Number: 606002
 OMNI Tracking No.: OMNI-00336
 Calibrated Orifice:

Average Gas Meter y Factor
0.985

Orifice Meter dH@
N/A

Calibration Date: 07/17/18
 Calibrated by: B. Davis
 Calibration Frequency: Six months
 Next Calibration Due: 1/17/2019
 Instrument Range: 1.000 cfm
 Standard Temp.: 68 oF
 Standard Press.: 29.92 "Hg
 Barometric Press., Pb: 30.12 "Hg
 Signature/Date: *B. Davis* 1/17/2018

Previous Calibration Comparison

Date	<u>1/17/2018</u>	Acceptable Deviation (5%)	Deviation
y Factor	<u>0.979</u>	0.04895	0.006
Acceptance	Acceptable		

Current Calibration

Acceptable y Deviation	0.020
Maximum y Deviation	0.003
Acceptable dH@ Deviation	N/A
Maximum dH@ Deviation	N/A
Acceptance	Acceptable

Reference Standard *

Standard	Model	Standard Test Meter
Calibrator	S/N	<u>OMNI-00001</u>
	Calib. Date	<u>30-Oct-17</u>
	Calib. Value	<u>0.9977</u> y factor (ref)

Calibration Parameters	Run 1	Run 2	Run 3
Reference Meter Pressure ("H2O), Pr	<u>0.00</u>	<u>0.00</u>	<u>0.00</u>
DGM Pressure ("H2O), Pd	<u>1.91</u>	<u>1.20</u>	<u>0.80</u>
Initial Reference Meter	<u>572.4</u>	<u>577.5</u>	<u>582.9</u>
Final Reference Meter	<u>577.4</u>	<u>582.604</u>	<u>588.1</u>
Initial DGM	<u>0</u>	<u>0</u>	<u>0</u>
Final DGM	<u>5.061</u>	<u>5.245</u>	<u>5.34</u>
Temp. Ref. Meter (°F), Tr	<u>86.0</u>	<u>86.0</u>	<u>78.0</u>
Temperature DGM (°F), Td	<u>90.0</u>	<u>95.0</u>	<u>86.0</u>
Time (min)	<u>23.5</u>	<u>30.0</u>	<u>37.8</u>
Net Volume Ref. Meter, Vr	5.000	5.104	5.200
Net Volume DGM, Vd	5.061	5.245	5.34
Gas Meter y Factor =	0.988	0.984	0.984
Gas Meter y Factor Deviation (from avg.)	0.003	0.001	0.001
Orifice dH@	N/A	N/A	N/A
Orifice dH@ Deviation (from avg.)	N/A	N/A	N/A

where:

1. Deviation = |Average value for all runs - current run value|
- ** 2. $y = [V_r \times (y \text{ factor (ref)}) \times (P_b + (P_r / 13.6)) \times (T_d + 460)] / [V_d \times (P_b + (P_d / 13.6)) \times (T_r + 460)]$
- ** 3. $dH@ = 0.0317 \times P_d / (P_b (T_d + 460)) \times [(T_r + 460) \times \text{time}] / V_r]^2$

* Reference calibration is traceable to NIST through NIST Test # 40674, Kimble ASTM E1272, or NIST traceable laboratory

** Equations come from EPA Method 5

The uncertainty of measurement is $\pm 0.14 \text{ ft}^3/\text{min}$. This is based on the reference standard having a TAR (Test Accuracy Ratio) of at least 4:1.

DIFFERENTIAL PRESSURE GAUGE CALIBRATION DATA SHEET

Instrument to be calibrated: Pressure Transducer

Maximum Range: 0-2" WC ID Number: OMNI-00336

Calibration Instrument: Digital Manometer ID Number: OMNI-00395

Date: 7/18/18 By: B. Davis

This form is to be used only in conjunction with Standard Procedure C-SPC.

Range of Calibration Point ("WC)	Digital Manometer Input ("WC)	Pressure Gauge Response ("WC)	Difference (Input - Response)	% Error of Full Span*
0-20% Max. Range 0 - 0.4	0.045	0.041	0.003	0.20
20-40% Max. Range 0.4 - 0.8	0.446	0.447	0.001	0.05
40-60% Max. Range 0.8 - 1.2	0.900	0.901	0.001	0.05
60-80% Max. Range 1.2 - 1.6	1.589	1.592	0.003	0.20
80-100% Max. Range 1.6 - 2.0	1.902	1.908	0.006	0.30

*Acceptable tolerance is 4%.

The uncertainty of measurement is ± 0.4 " WC. This is based on the reference standard having a TAR (Test Accuracy Ratio) of at least 4:1.

Technician signature:  Date: 7/18/18

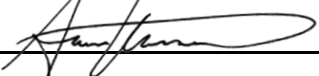
Reviewed by:  Date: 7/20/18

Temperature Calibration EPA Method 28R, ASTM 2515								
BOOTH:		TEMPERATURE MONITOR TYPE:				EQUIPMENT NUMBER:		
Mobile		National Instruments Logger				00335, 00336		
REFERENCE METER EQUIPMENT NUMBER: 00373				Calibration Due Date: 8/02/17				
CALIBRATION PERFORMED BY:			DATE:		AMBIENT TEMPERATURE:		BAROMETRIC PRESSURE:	
B. Davis			7/17/18		76		30.12	
Input Temperature (F)	Ambient	Meter A					Tunnel	FB Interior
			Meter B	Filter A	Filter B			
0	0	1	1	1	1	0	0	
100	100	101	101	100	100	100	100	
300	300	300	300	300	300	300	300	
500	500	501	500	500	500	500	500	
700	700	700	700	700	700	700	700	
1000	1000	1001	1000	1000	1000	1000	1000	

Input (F)	FB Top	FB Bottom	FB Back	FB Left	FB Right	Imp A	Imp B	Cat	Stack
0	0	0	0	0	0	1	1	1	0
100	100	100	100	100	100	101	101	101	100
300	300	300	300	300	300	300	300	300	300
500	500	500	500	500	500	500	500	500	500
700	700	700	700	700	700	700	700	700	700
1000	1000	1000	1000	1000	1000	1000	1000	1000	1000

1500
2000

1500
2000

Technician signature:  Date: 7/17/18

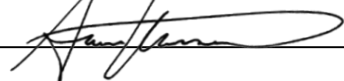
Reviewed By:  Date: 7/20/18

VWR Temperature Hygrometer Calibration Procedure and Data Sheet

Frequency: Every Two Years

Step 1: Locate NIST traceable standard.

Step 2: Place unit to be calibrated, tracking No. OMNI-00592, inside OMNI desiccator box on the same shelf with the NIST traceable standard.

Step 3: After a period of not less than four hours record the temperature and humidity of both units in the spaces provide below.

Step 4: If the unit to be calibrated matches the NIST standard within $\pm 4\%$, it is acceptable. If not, the unit needs to be sent to a repair company or replaced.

Verification Data:

Date: 1/29/19
1/29/19 Technician: B. Davis

Time in desiccator: 0840 Recording time: 1415

NIST Standard Temperature: 70.2 °F NIST Standard Humidity: 14.6

Test Unit Temperature Reading: 69.9 °F Test Unit Humidity Reading: 12.1

Test unit OMNI-00592 is X or was not within acceptable limits.

Technician Signature: [Signature]

Comments: A difference of 2.5% was found, with a full scale of 90%
on the instrument this gives a 2.77% deviation.

Certificate of Calibration

Certificate Number: **686722**



JJ Calibrations, Inc.
 7007 SE Lake Rd
 Portland, OR 97267-2105
 Phone 503.786.3005
 FAX 503.786.2994

Omni-Test Laboratories
 13327 NE Airport Way
 Portland, OR 97230



PO: **180192**
 Order Date: **10/22/2018**
 Authorized By: **N/A**
 Calibrated on: **10/30/2018**
 *Recommended Due: **10/30/2019**
 Environment: **22 °C 44 % RH**
 * As Received: **Limited**
 * As Returned: **Limited**
 Action Taken: **Calibrated**
 Technician: **111**

Property #: **OMNI-00410**
 User: **N/A**
 Department: **N/A**
 Make: **Dwyer**
 Model: **1430**
 Serial #: **OMNI-00410**
 Description: **Microtector**
 Procedure: **DCN 500908**
 Accuracy: **±0.00025" WC**

Remarks: * Many factors may cause the unit to drift out of calibration before the recommended due date. Any reported error is the absolute value between the reference and the unit. Uncertainties include the effects of the unit.

Previous limitation of micrometer head calibrated only continued. .001" reading micrometer head ±.001" (LSD) tolerance applied.

Standards Used

Std ID	Manufacturer	Model	Nomenclature	Due Date	Trace ID
541A	Select	E8FED2	Gage Block Set, 8pc	12/18/2018	663864

Measurement Data

Parameter	Measurement Description	Range	Unit	Reference	Min	Max	*Error	UUT	Uncertainty
Before/After Length									Accredited = ✓
		Inch		0.1300	0.129	0.131	0.001	0.129 Inch	1.1E-03 ✓
		Inch		0.3850	0.384	0.386	0.001	0.384 Inch	1.1E-03 ✓
		Inch		0.6150	0.614	0.616	0.001	0.614 Inch	1.1E-03 ✓
		Inch		0.8700	0.869	0.871	0.001	0.869 Inch	1.1E-03 ✓
		Inch		1.0000	0.999	1.001	0.001	0.999 Inch	1.1E-03 ✓

JJ Calibrations, Inc. certifies that this instrument has been calibrated in accordance with the JJ Calibrations Quality Assurance Manual with the stated procedure using standards that are traceable to the National Institute of Standards and Technology (NIST), or other National Measurement Institutes (NMI's), or by using natural physical constants, intrinsic standards or ratio calibration techniques. The quality system and this certificate are in compliance with ANSI/NCCL Z540-1-1994, ISO/IEC 17025-2005, ISO 10012-1, the ISO 9000 family and QS 9000. The expanded uncertainties of measurements for this calibration are based upon 95% (2 sigma) confidence limits. Unless otherwise stated, a test accuracy ratio (TAR) of 4:1, if achievable, is maintained. The results reported herein apply only to the calibration of the item described above. This report may not be reproduced, except in full, without prior written consent of JJ Calibrations, Inc.
 JJ Calibrations, Inc. quality system has been assessed and accredited to ISO/IEC 17025:2005.

 Reviewer

3 Issued 10/31/2018 Rev # 15

 Inspector

NIST Stopwatch Calibration, Time Proficiency Testing Procedure and Data Sheet

Date: 2/28/2018 User/Technician: Bruce Davis Pass Fail

NIST traceable stopwatch OMNI tracking number: OMNI-00565 Last Cal: 6/27/17

Stopwatch to be tested for time proficiency OMNI tracking number: OMNI-00443

1. Start the NIST traceable stopwatch: at a predetermined time (i.e. 1.00 minutes), the technician shall start the watch being tested. When 15.00 seconds have passed (i.e. the NIST traceable stopwatch reads 1 minute, 15 seconds), the technician shall stop the watch being tested. Record the target time interval (i.e. 15.00 seconds). Repeat this step twice and record the data.
2. Repeat step #1 for each of the following target time intervals: 30.00 seconds, 10.00 minutes, and 30 minutes.
3. If the delta between the target time and measured time is less than 5% of the target time interval or 2.00 seconds (whichever is less), then the technician has demonstrated proficiency with the specific instrument utilized in the proficiency test. The proficiency is valid for a period of 12 months.
4. Archive the proficiency test data and information, including the effective date and expiration date of the proficiency, in the equipment record for the instrument involved.

Target time: 15.00 seconds #1 Measured time: 14.96 #2 Measured time: 15.02 #3 Measured time: 15.01

Target time: 30.00 seconds #1 Measured time: 30.01 #2 Measured time: 29.92 #3 Measured time: 30.01

Target time: 45.00 seconds #1 Measured time: 45.01 #2 Measured time: 44.92 #3 Measured time: 44.92

Target time: 60.00 seconds #1 Measured time: 1.00.10 #2 Measured time: 1.00.15 #3 Measured time: 59.96

Target time: 10.00 minutes #1 Measured time: 9.59.98 #2 Measured time: 9.59.93 #3 Measured time: 10.00.07

Target time: 30.00 minutes #1 Measured time: 30.00.14 #2 Measured time: 30.00.04 #3 Measured time: 30.00.14

The uncertainty of measurement is ± 1 sec. This is based on the reference standard having a TAR (Test Accuracy Ratio) of at least 4:1.

This calibration procedure is confirmed by the manufacturer as a proper method for evaluating the accuracy of timers.

Technician Signature:  Date: 2/28/18

Reviewed by:  Date: 3/1/18

Certificate of Calibration

Certificate Number: 675241



JJ Calibrations, Inc.

7007 SE Lake Rd
Portland, OR 97267-2105
Phone 503.786.3005
FAX 503.786.2994

Omni-Test Laboratories
13327 NE Airport Way
Portland, OR 97230

PO: 180171
Order Date: 05/10/2018
Authorized By: N/A

Property #: OMNI-00430
User: N/A
Department: N/A
Make: Delmhorst
Model: MCS-1
Serial #: OMNI 00430
Description: Moisture Calibrator
Procedure: Raw Data
Accuracy: Raw Data

Calibrated on: 05/13/2018
*Recommended Due: 05/13/2019
Environment: 22 °C 40 % RH
As Received: Other - See Remarks
As Returned: Other - See Remarks
Action Taken: Calibrated
Technician: 40

Remarks: * Many factors may cause the unit to drift out of calibration before the recommended due date. Any reported error is the absolute value between the reference and the unit.

RECEIVED AND RETURNED WITH POUCH.

Standards Used

Std ID	Manufacturer	Model	Nomenclature	Due Date	Trace ID
281A	Hewlett-Packard	3458A	Digital Bench Multimeter, 8.5	12/11/2018	663526

Measurement Data

Parameter	Measurement Description	Range Unit	Reference	Min	Max	*Error	UUT
Before/After							
Resistance							
12 %		120 MOhm	0.00000	0.0000	0.0000	120.0193	120.0193 MOhm
22 %		1.1 MOhm	0.0000000	0.000000	0.000000	1.100332	1.100332 MOhm

JJ Calibrations, Inc. certifies that this instrument has been calibrated in accordance with the JJ Calibrations Quality Assurance Manual with the stated procedure using standards that are traceable to the National Institute of Standards and Technology (NIST), or other National Measurement Institutes (NMI's), or by using natural physical constants, intrinsic standards or ratio calibration techniques. The quality system and this certificate are in compliance with ANSI/NCSL Z540-1-1994, ISO/IEC 17025-2005, ISO 10012-1, the ISO 9000 family and QS 9000. The expanded uncertainties of measurements for this calibration are based upon 95% (2 sigma) confidence limits. Unless otherwise stated, a test accuracy ratio (TAR) of 4:1, if achievable, is maintained. The results reported herein apply only to the calibration of the item described above. This report may not be reproduced, except in full, without prior written consent of JJ Calibrations, Inc.
JJ Calibrations, Inc. quality system has been assessed and accredited to ISO/IEC 17025:2005.

Reviewer

Issued 05/14/2018

Rev # 15

Inspector

CALIBRATION RECORD

VANEOMETER AIR VELOCITY METER OMNI #00265

CALIBRATIONS SERVICE RECORD

DATE	BY	RESULTS	DATE OF NEXT CALIBRATION
10/5/10	BO	INSTALLED NEW VANE FR. FACTORY	4/5/11
4/6/11	SO	" " " " "	10/6/11
7/21/15	JC	Installed new vane from manufacturer	1/21/16
3/4/16	BD	Installed new Vane from manufacturer	9/4/16
8/30/16	BD	Installed new vane from manufacturer	3/7/17 3/30/16
3/9/17	BD	Installed new Vane from Manufacturer	9/9/17
9/13/17	BD	Installed new Vane from Manufacturer	3/13/18
4/3/18	BR	Installed new Vane from Manufacturer	10/3/18
10/16/18	BD	Installed new Vane from Manufacturer	4/16/18

Example Calculations

Equations and Sample Calculations – ASTM E2780 & E2515

Manufacturer: Hearth & Home
Model: Aspen C3
Run: 3
Category: II

Equations used to calculate the parameters listed below are described in this appendix. Sample calculations are provided for each equation. The raw data and printout results from a sample run are also provided for comparison to the sample calculations.

M_{Sdb} – Weight of test fuel spacers, dry basis, kg

M_{Cdb} – Weight of test fuel crib, excluding nails and spacers, dry basis, kg

D_{Cdb} - Density of fuel crib, excluding spacers and nails, dry basis, lbs/ft³

M_{FTAdb} - Total weight of fuel crib excluding nails, dry basis, kg

BR – Dry burn rate, kg/hr

V_s – Average gas velocity in the dilution tunnel, ft/sec

Q_{sd} – Average gas flow rate in dilution tunnel, dscf/hr

$V_{m(std)}$ – Volume of gas sampled, corrected to dry standard conditions, dscf

m_n – Total particulate matter collected, mg

C_s - Concentration of particulate matter in tunnel gas, dry basis, corrected to standard conditions, g/dscf

E_T – Total particulate emissions, g

PR - Proportional rate variation

PM_R – Particulate emissions for test run, g/hr

PM_F – Particulate emission factor for test run, g/dry kg of fuel burned

M_{Sdb} – Weight of test fuel spacers, dry basis, kg

ASTM E2780 equation (1)

$$M_{Sdb} = (M_{Swb}) (100 / (100 + FM_S))$$

Where,

FM_S = average fuel moisture of test fuel spacers, % dry basis

M_{Swb} = weight of test fuel spacers, wet basis, kg

Sample Calculation:

$$FM_S = 19.7 \%$$

$$M_{Swb} = 1.9 \text{ lbs}$$

0.4536 = Conversion factor from lbs to kg

$$M_{Sdb} = [(1.9 \times 0.4536) (100 / (100 + 19.7))]$$

$$M_{Sdb} = \mathbf{0.7 \text{ kg}}$$

M_{Cdb}– Weight of test fuel crib, excluding nails and spacers, dry basis, kg
ASTM E2780 equation (2)

$$M_{Cdb} = \Sigma[(M_{CPnwb})(100/(100 + FM_{CPn}))]$$

Where,

M_{CPnwb} = weight of each test fuel piece n in fuel crib, excluding nails and spacers, wet basis, kg

FM_{CPn} = Average fuel moisture of test fuel n in fuel crib, % dry basis

Sample Calculation (test fuel piece 1):

$$M_{CPnwb} = 1.7$$

$$FM_{CPn} = 20.3$$

$$= 1.7 (100/(100+ 20.3)$$

$$= 1.4 \text{ lbs}$$

Total crib weight, excluding spacer 5.70 lbs

$$M_{Cdb} = \mathbf{2.59 \text{ kg}}$$

D_{Cdb} - Density of fuel crib, excluding spacers and nails, dry basis, lbs/ft³
ASTM E2780 equation (3)

$$D_{Cdb} = M_{Cdb}/V_C$$

Where,

$$V_C = \text{Volume of fuel crib, ft}^3$$

Sample calculation:

$$V_C = 336 \text{ in}^3$$

$$1728 = \text{conversion from in}^3 \text{ to ft}^3$$

$$D_{Cdb} = 5.70 / 336 * 1728$$

$$= \mathbf{29.3} \text{ lbs/ft}^3$$

M_{FTAdb} - Total weight of fuel crib excluding nails, dry basis, kg
ASTM E2780 equation (4)

$$M_{FTAdb} = M_{Sdb} + M_{Cdb}$$

Sample calculation:

$$M_{FTAdb} = 0.72 + 2.59$$

$$= \mathbf{3.31 \text{ kg}}$$

BR – dry burn rate, kg/hr

ASTM E2780 equation (5)

$$BR = \frac{60 M_{FTAdb}}{\theta}$$

Where,

θ = Total length of test run, min

Sample Calculation:

$$M_{Bdb} = 3.31 \quad \text{kg}$$

$$\theta = 160 \quad \text{min}$$

$$BR = \frac{60 \times 3.31}{160}$$

$$BR = 1.24 \quad \text{kg/hr}$$

V_s – Average gas velocity in the dilution tunnel, ft/sec

ASTM E2515 equations (9)

$$V_s = F_p \times k_p \times C_p \times (\sqrt{\Delta P})_{avg} \times \sqrt{\frac{T_{s(avg)}}{P_s \times M_s}}$$

Where:

- F_p = Adjustment factor for center of tunnel pitot tube placement, $F_p = \frac{V_{strav}}{V_{scent}}$, ASTM E2515 Equation (1)
- V_{scent} = Dilution tunnel velocity calculated after the multi-point pitot traverse at the center, ft/sec
- V_{strav} = Dilution tunnel velocity calculated after the multi-point pitot traverse, ft/sec
- k_p = Pitot tube constant, 85.49
- C_p = Pitot tube coefficient: 0.99, unitless
- ΔP* = Velocity pressure in the dilution tunnel, in H₂O
- T_s = Absolute average gas temperature in the dilution tunnel, °R; (°R = °F + 460)
- P_s = Absolute average gas static pressure in dilution tunnel, = P_{bar} + P_g, in Hg
- P_{bar} = Barometric pressure at test site, in. Hg
- P_g = Static pressure of tunnel, in. H₂O; (in Hg = in H₂O/13.6)
- M_s = **The dilution tunnel wet molecular weight; M_s = 28.78 assuming a dry weight of 29 lb/lb-mole

Sample calculation:

$$F_p = \frac{14.84}{16.41} = 0.904$$

$$V_s = 0.904 \times 85.49 \times 0.99 \times 0.233 \times \left(\frac{83.5 + 460}{\left(\left(\frac{29.61}{13.6} + \frac{-0.21}{13.6} \right) \times 28.78 \right)^{1/2}} \right)$$

$$V_s = 14.24 \text{ ft/s}$$

*The ASTM test standard mistakenly has the square root of the average delta p instead of the average of the square root of delta p. The current EPA Method 2 is also incorrect. This was verified by Mike Toney at EPA.

**The ASTM test standard mistakenly identifies M_s as the dry molecular weight. It should be the wet molecular weight as indicated in EPA Method 2.

Q_{sd} – Average gas flow rate in dilution tunnel, dscf/hr

ASTM E2515 equation (3)

$$Q_{sd} = 3600 \times (1 - B_{ws}) \times v_s \times A \times \frac{T_{std}}{T_{s(avg)}} \times \frac{P_s}{P_{std}}$$

Where:

- 3600 = Conversion from seconds to hours (ASTM method uses 60 to convert in minutes)
- B_{ws} = Water vapor in gas stream, proportion by volume; assume 2%
- A = Cross sectional area of dilution tunnel, ft²
- T_{std} = Standard absolute temperature, 528 °R
- P_s = Absolute average gas static pressure in dilution tunnel, = P_{bar} + P_g, in Hg
- T_{s(avg)} = Absolute average gas temperature in the dilution tunnel, °R; (°R = °F + 460)
- P_{std} = Standard absolute pressure, 29.92 in Hg

Sample calculation:

$$Q_{sd} = 3600 \times (1 - 0.02) \times 14.24 \times 0.196 \times \frac{528}{83.5 + 460} \times \frac{29.6 + \frac{-0.21}{13.6}}{29.92}$$

Q_{sd} = **9479.4** dscf/hr

$V_{m(std)}$ – Volume of Gas Sampled Corrected to Dry Standard Conditions, dscf
 ASTM E2515 equation (6)

$$V_{m(std)} = K_1 V_m Y \frac{P_{bar} + \left(\frac{\Delta H}{13.6}\right)}{T_m}$$

Where:

- K_1 = 17.64 °R/in. Hg
- V_m = Volume of gas sample measured at the dry gas meter, dcf
- Y = Dry gas meter calibration factor, dimensionless
- P_{bar} = Barometric pressure at the testing site, in. Hg
- ΔH = Average pressure differential across the orifice meter, in. H₂O
- T_m = Absolute average dry gas meter temperature, °R

Sample Calculation:

Using equation for Train 1:

$$V_{m(std)} = 17.64 \times 26.016 \times 0.986 \times \frac{\left(29.61 + \frac{1.34}{13.6} \right)}{\left(76.8 + 460 \right)}$$

$$V_{m(std)} = \mathbf{25.038} \text{ dscf}$$

Using equation for Train 2:

$$V_{m(std)} = 17.64 \times 26.054 \times 0.985 \times \frac{\left(29.61 + \frac{1.05}{13.6} \right)}{\left(78.7 + 460 \right)}$$

$$V_{m(std)} = \mathbf{24.943} \text{ dscf}$$

Using equation for ambient train:

$$V_{m(std)} = 17.64 \times 0.00 \times 0 \times \frac{\left(29.61 + \frac{0.00}{13.6} \right)}{\left(66.8 + 460 \right)}$$

$$V_{m(std)} = \mathbf{0} \text{ dscf}$$

m_n – Total Particulate Matter Collected, mg

ASTM E2515 Equation (12)

$$m_n = m_p + m_f + m_g$$

Where:

m_p = mass of particulate matter from probe, mg

m_f = mass of particulate matter from filters, mg

m_g = mass of particulate matter from filter seals, mg

Sample Calculation:

Using equation for Train 1 (first hour):

$$m_n = 0.0 + 0.0 + 0.0$$

$$m_n = 0.0 \text{ mg}$$

Using equation for Train 1 (post-first hour):

$$m_n = 0.6 + 4.2 + 1.3$$

$$m_n = 6.1 \text{ mg}$$

Train 1 aggregate:

$$m_n = 0.0 + 6.1$$

$$m_n = \mathbf{6.1} \text{ mg}$$

Using equation for Train 2:

$$m_n = 0.4 + 4.2 + 1$$

$$m_n = \mathbf{5.6} \text{ mg}$$

C_s - Concentration of particulate matter in tunnel gas, dry basis, corrected to standard conditions, g/dsc
ASTM E2515 equation (13)

$$C_s = K_2 \times \frac{m_n}{V_{m(\text{std})}}$$

Where:

K₂ = Constant, 0.001 g/mg

m_n = Total mass of particulate matter collected in the sampling train, mg

V_{m(std)} = Volume of gas sampled corrected to dry standard conditions, dscf

Sample calculation:

For Train 1:

$$C_s = 0.001 \times \frac{6.1}{25.04}$$

$$C_s = \mathbf{0.00024} \text{ g/dscf}$$

For Train 2

$$C_s = 0.001 \times \frac{5.6}{24.94}$$

$$C_s = \mathbf{0.00022} \text{ g/dscf}$$

For Ambient Train

$$C_r = 0.001 \times \frac{0.0}{0}$$

$$C_r = \mathbf{0} \text{ g/dscf}$$

E_T – Total Particulate Emissions, g

ASTM E2515 equation (15)

$$E_T = (C_s - C_r) \times Q_{std} \times \theta$$

Where:

- C_s = Concentration of particulate matter in tunnel gas, g/dscf
- C_r = Concentration particulate matter room air, g/dscf
- Q_{std} = Average dilution tunnel gas flow rate, dscf/hr
- θ = Total time of test run, minutes

Sample calculation:

For Train 1

$$E_T = (\underline{0.000244} - 0) \times \underline{9479.4} \times \underline{160} / 60$$
$$E_T = \underline{6.16} \text{ g}$$

For Train 2

$$E_T = (\underline{0.000225} - 0) \times \underline{9479.4} \times \underline{160} / 60$$
$$E_T = \underline{5.68} \text{ g}$$

Average

$$E = \underline{5.92} \text{ g}$$

Total emission values shall not differ by more than 7.5% from the total average emissions

$$7.5\% \text{ of the average} = \underline{0.44}$$

$$\text{Train 1 difference} = \underline{0.24}$$

$$\text{Train 2 difference} = \underline{0.24}$$

PR - Proportional Rate Variation

ASTM E2515 equation (16)

$$PR = \left[\frac{\theta \times V_{mi} \times V_s \times T_m \times T_{si}}{\theta_i \times V_m \times V_{si} \times T_{mi} \times T_s} \right] \times 100$$

Where:

- θ = Total sampling time, min
- θ_i = Length of recording interval, min
- V_{mi} = Volume of gas sample measured by the dry gas meter during the "ith" time interval, dcf
- V_m = Volume of gas sample as measured by dry gas meter, dcf
- V_{si} = Average gas velocity in the dilution tunnel during the "ith" time interval, ft/sec
- V_s = Average gas velocity in the dilution tunnel, ft/sec
- T_{mi} = Absolute average dry gas meter temperature during the "ith" time interval, °R
- T_m = Absolute average dry gas meter temperature, °R
- T_{si} = Absolute average gas temperature in the dilution tunnel during the "ith" time interval, °R
- T_s = Absolute average gas temperature in the dilution tunnel, °R

Sample calculation (for the first 1 minute interval of Train 1):

$$PR = \left(\frac{160 \times 0.8 \times 14.24 \times (84.0 + 460) \times (76.8 + 460)}{5 \times 26.02 \times 14.73 \times (83.5 + 460) \times (73.0 + 460)} \right) \times 100$$

$$PR = \underline{96} \%$$

PM_R – Particulate emissions for test run, g/hr

ASTM E2780 equation (6)

$$PM_R = 60 (E_T/\theta)$$

Where,

E_T = Total particulate emissions, grams

θ = Total length of full integrated test run, min

Sample Calculation:

$$E_T (\text{Dual train average}) = 5.92 \text{ g}$$

$$\theta = 160 \text{ min}$$

$$PM_R = 60 \times (5.92 / 160)$$

$$PM_R = 2.22 \text{ g/hr}$$

PM_F – Particulate emission factor for test run, g/dry kg of fuel burned
ASTM E2780 equation (7)

$$PM_F = E_T / M_{FTAdb}$$

Sample Calculation:

$$E_T (\text{Dual train average}) = 5.92 \text{ g}$$

$$M_{Bdb} = 3.31 \text{ kg}$$

$$PM_F = 5.92 / 3.31$$

$$PM_F = \mathbf{1.79} \text{ g/kg}$$

Section 5

Labeling & Owner's Manual



MODEL / MODÈLE: "Aspen C3"
 LISTED SOLID FUEL ROOM HEATER BURNING FIREPLACE STOVE
 HOMOLOGUE POELE A COMBUSTIBLE SOLIDES
 SUITABLE FOR MOBILE-HOME INSTALLATION

Serial No. **HF**
 N° de série:

BARCODE LABEL

Report #/Rapport #0135WS044S / 0135WS044E
 Tested to / Testé à: ASTM E2515, ASTM E2780, UL 1482-2011, ULC-S627-00

Install and Use Only In Accordance With Vermont Castings Installation and Operation Instructions.

Contact Local Building or Fire Officials About Restrictions and Installation Inspection In Your Area.

Install only with legs provided in accordance with installation instructions. Do not obstruct the space under the heater.

Fuel: For use with solid wood fuel ONLY . Do not burn other fuels.

Build fire directly on grate. Do not elevate fire. Keep door fully closed while operating. Do Not Overfire. If Heater or Chimney Connector Glows, You Are Overfiring. Keep combustible materials and furnishings well away from the stove.

Chimney: Use a minimum 6" or 8" diameter, factory-built high temperature (H.T.) chimney which is listed to UL-103-1985 (2100°F) or 8"X8" nominal or larger approved masonry chimney with flue liner. Do Not Connect This Unit To A Chimney Flue Serving Another Appliance. Inspect and Clean Chimney Frequently- Under Certain Conditions of Use, Creosote Buildup May Occur Rapidly.

Chimney Connector: Use a minimum 6" or 8" diameter 24 gauge chimney connector. Install chimney connector at least 24" from ceiling. Refer to local building codes and Vermont Castings Owner's Guide for special precautions for passing a chimney or chimney connector through a combustible wall or ceiling.

Floor Protection U.S.: Use a noncombustible floor protector such as 1/4" non-asbestos mineral board or equivalent or 24 gauge sheet metal. The floor protector is required under the stove and must extend 16" from the front, 6" from the sides and rear. It must extend under the chimney connector and 2" to either side. The floor protector may be covered with a noncombustible decorative material if desired. Without Vermont Castings Bottom Heat Shield Kit, only installations over a totally noncombustible floor are acceptable, such as unpainted concrete over earth.

Floor Protection Canada: Operate only with Vermont Castings Bottom Heat Shield Kit No.1895 in place. When installed on a combustible floor, a noncombustible floor protector is required under the heater. The floor protector must extend 460 mm (18 in.) to the front and 200 mm (8 in.) to the sides and rear.

Optional Components, U.S.: Outside Air Kit No. 1897, Mobile Home Kit No.1898.

Most vertical installations require a ceiling heat shield and a flue collar heat shield to be installed. Consult your Owner's Manual.

MINIMUM CLEARANCES TO COMBUSTIBLE CONSTRUCTION / MINIMUM DE DEGAGEMENT JUSQU'A LA CONSTRUCTION COMBUSTIBLE

Replace glass only with Vermont Castings glass, No. 3-40-950144.

Veillez a n'installer votre poele et a n'utiliser que conformement aux directives d'installation et de fonctionnement du fabricant Installer seulement avec les pattes fournies, en conformite avec les instructions du fabricant. Ne pas encombre l'espace sous le poele.

Combustible: Utiliser seulement du bois Ne brulez pas d'autres combustibles. Faire le feu directement sur la grille. Veillez a ce que les portes soient fermees pendant le fonctionnement.

Remplacer les vitres de ceramique par celles de Vermont Castings seulement, (No. de piece 3-40-950144).

Protege Plancher Canada: Utilisez seulement avec le kit du deflecteur de chaleur de bas du Vermont Castings (No.de pilce1895). Lorsqu'installe sur un plancher combustible, une protection non-combustible est requise.

US ENVIRONMENTAL PROTECTION AGENCY

Certified to comply with 2020 US particulate emissions standard using crib wood at 1.99 g/hr., Certified to comply with 2020 particulate emission standards for single burn rate heaters. This single burn rate wood heater is not approved for use with a flue damper. It is against Federal Regulations to operate this wood heater in a manner inconsistent with operating instructions in the Owner's Manual.

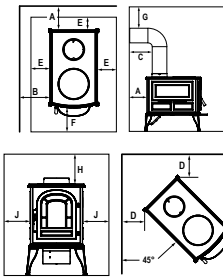

A: W/ No Shields	13 in. (330 mm)
A: W/ Wall Shield	9 in. (230 mm)
A: W/ Rear & Connector Shields	9 in. (230 mm)*
B: W/ No Shields	24 in. (610 mm)
B: W/ Wall Shield	16 in. (405 mm)
C: W/ No Wall Shield	15 in. (380 mm)
C: W/ Wall Shield	11 in. (280 mm)
C: W/ Rear & Connector Shields	13 in. (330 mm)
D: W/ No Shields	13 in. (330 mm)
D: W/Wall Shield	8 in. (205 mm)
D: W/ Rear & Sides-U.S.	13 in. (330 mm)*
E: From Rear & Sides-U.S.	6 in. (150 mm)
E: From Rear & Sides- Canada	8 in. (205 mm)
F: From Front- U.S.	16 in. (405 mm)
F: From Front-Canada	18 in.(460mm)
G: From Connector To Ceiling	18 in. (460 mm)
H: From Stove to Mantel or Trim	15 in. (380 mm)*
J: From Stove to Side Trim	12 in. (305 mm)*

CAUTION: HOT WHILE IN OPERATION - DO NOT TOUCH - KEEP CHILDREN AND CLOTHING AWAY - CONTACT MAY CAUSE SKIN BURNS - SEE NAMEPLATE AND INSTRUCTIONS. KEEP FURNISHINGS AND OTHER COMBUSTIBLE MATERIALS A CONSIDERABLE DISTANCE AWAY FROM THE APPLIANCE



ATTENTION: CHAUD LORS DU FONCTIONNEMENT - NE TOUCHEZ PAS L'APPAREIL - GARDEZ LES ENFANTS ET LES VÊTEMENTS ÉLOIGNÉS - TOUT CONTACT PEUT ENTRAÎNER DES BRÛLURES DE LA PEAU. RÉFÉREZ - VOUS À LA PLAQUE SIGNALÉTIQUE ET AU MODE D'EMPLOI. GARDEZ LE MOBILIER ET LES AUTRES MATÉRIAUX COMBUSTIBLES BIEN À L'ÉCART DE L'APPAREIL.

VERMONT CASTINGS

Made in U.S.A. of US and imported parts. / Fabriqué aux États-Unis-d'Amérique par des pièces d'origine américaine et pièces importées.

Date of Manufacture / Date de fabrication:

2019	2020	2021	JAN	FEB	MAR	APR	MAY	JUN	JUL	AUG	SEP	OCT	NOV	DEC
■	■	■	■	■	■	■	■	■	■	■	■	■	■	■

Manufactured by / Fabriqué par: Hearth and Home Technologies 352 Mountain House Road, Halifax PA 17032

8390-950_R1

LABEL TICKET	
ECO: 89741	LABEL SIZE: 11 in. x 4.375 in.
PART # / REV: 8390-950	ADHESIVE:
ORIGINATOR: Spidlet	MATERIAL: 24 Gauge Aluminum
DATE: 02/13/19	INK: Screened Red and Black as Shown
<p>352 Mountain House Road Halifax, PA 17032</p>	ALL CAUTION LITERATURE IN RED (1) Hole = .156 x .250, (1) Hole = Ø.25, Corners .062 Barcode label must have the serial number on it. The barcode label must be able to read Code 39 Full ASCII.

Installation & Operating Manual

Installation and Appliance Setup - Care and Operation

INSTALLER: Leave this manual with party responsible for use and operation.

OWNER: Retain this manual for future reference.

Call your dealer for questions on Installation, Operation, or Service.

NOTICE: SAVE THESE INSTRUCTIONS

VERMONT  CASTINGS

Aspen C3 Wood Stove

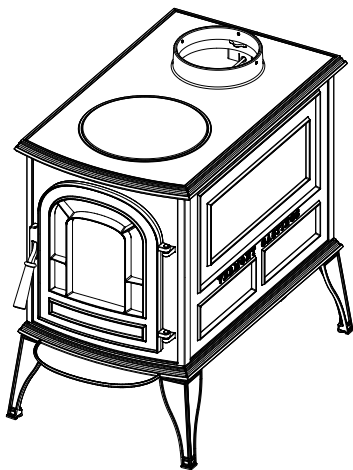

For use in the United States and Canada



Installation and service of this appliance should be performed by qualified personnel. Hearth & Home Technologies recommends HHT Factory Trained or NFI certified professionals.



WARNING



HOT SURFACES!

GLASS AND OTHER SURFACES ARE HOT DURING OPERATION AND COOL DOWN.

HOT, WILL CAUSE BURNS.

- DO NOT TOUCH GLASS UNTIL IT IS COOLED
- NEVER ALLOW CHILDREN TO TOUCH GLASS
- KEEP CHILDREN AWAY
- CAREFULLY SUPERVISE CHILDREN IN SAME ROOM AS FIREPLACE.
- ALERT CHILDREN AND ADULTS TO HAZARDS OF HIGH TEMPERATURES.

HIGH TEMPERATURES MAY IGNITE CLOTHING OR OTHER FLAMMABLE MATERIALS.

- KEEP CLOTHING, FURNITURE, DRAPERIES AND OTHER FLAMMABLE MATERIALS AWAY.

WARNING



PLEASE READ THIS ENTIRE MANUAL BEFORE INSTALLATION AND USE OF THIS WOOD-BURNING ROOM HEATER. FAILURE TO FOLLOW THESE INSTRUCTIONS COULD RESULT IN PROPERTY DAMAGE, BODILY INJURY OR EVEN DEATH.

- DO NOT STORE OR USE GASOLINE OR OTHER FLAMMABLE VAPORS AND LIQUIDS IN THE VICINITY OF THIS OR ANY OTHER APPLIANCE.
- DO NOT OVERFIRE - IF ANY EXTERNAL PART STARTS TO GLOW, YOU ARE OVERFIRING. CLOSE AIR CONTROLS. OVERFIRING WILL VOID YOUR WARRANTY.
- COMPLY WITH ALL MINIMUM CLEARANCES TO COMBUSTIBLES AS SPECIFIED. FAILURE TO COMPLY MAY CAUSE A HOUSE FIRE.

The French language version of this manual is available online: www.vermontcastings.com

La version française de ce manuel est disponible en ligne: www.vermontcastings.com

Thank you for choosing a Vermont Castings Aspen C3 to meet your heating needs. We're confident you will find the Aspen C3 to be an effective wood-burning heater incorporating modern, non-catalytic combustion technology with the timeless aesthetic appeal of its Vermont Castings lineage.

The Aspen C3 achieves high-efficiency through precisely calibrated delivery of primary and secondary air into a refractory-insulated firebox. Properly operated and maintained according to the guidelines in this manual, your Aspen C3 will provide safe, dependable, and economical heating for years to come.

The Aspen C3 is listed for burning wood fuel only. Do not burn other fuels.

The Aspen C3 complies with the standards set forth by the Federal Environmental Protection Agency, 40 CFR Part 60.532(b)(2), as stated on the permanent label attached to each stove.

We recommend that you hire a professional, solid-fuel stove technician to install your Aspen C3, or to advise you on the installation should you attempt to install it yourself. Consult the authority having local jurisdiction (such as a municipal building department, fire department, fire prevention bureau, etc.) before installation to determine the need for a building permit. Also, consult your insurance agent to be sure your installation complies with specific requirements that may vary locally.

In addition to directions on installation and operation, this manual includes directions on maintenance and assembly. Please read this entire manual before you install or operate your new room heater.

Save These Instructions For Future Reference.

This Label is located on the rear of the appliance. It contains important safety test information as well as the clearances to combustible materials. The label also contains the appliance serial number. For your records, copy your serial number and purchase date here.

Date of Purchase: _____

Serial #: _____

MODEL / MODÈLE: "Aspen C3"
LISTED SOLID FUEL ROOM HEATER BURNING FIREPLACE STOVE
HOMOLOGUE POÊLE À COMBUSTIBLE SOLIDES
SUITABLE FOR MOBILE-HOME INSTALLATION

Serial No. **HF** **BARCODE LABEL**

Report #/Rapport #0135WS044S / 0135WS044E
Listed to / Testé à: ASTM E2615, ASTM E2780, UL 1482-2011, UL-C-9827-00, CSA B415.1

Install and Use Only In Accordance With Vermont Castings Installation and Operation Instructions.
Contact Local Building or Fire Officials About Restrictions and Installation Inspection In Your Area.
Install only with legs provided in accordance with installation instructions. Do not obstruct the space under the heater.
Fuel: For use with solid wood fuel ONLY. Do not burn other fuels.
Build fire directly on grate. Do not elevate fire. Keep door fully closed while operating. Do Not Overfire. If Heater or Chimney Connector Glows, You Are Overfiring. Keep combustible materials and furnishings well away from the stove.
Chimney: Use a minimum 6" or 8" diameter, factory-built high temperature (R17) chimney which is listed to UL-103-1985 (2100°F) or 8X8" nominal or larger approved masonry chimney with flue liner. Do Not Connect This Unit To A Chimney Flue Serving Another Appliance. Inspect and Clean Chimney Frequently - Under Certain Conditions of Use, Creosote Buildup May Occur Rapidly.
Chimney Connector: Use a minimum 6" or 8" diameter 24 gauge chimney connector. Install chimney connector at least 24" from ceiling. Refer to local building codes and Vermont Castings Owner's Guide for special precautions for passing a chimney or chimney connector through a combustible wall or ceiling.
Floor Protection U.S.: Use a noncombustible floor protector such as 1/4" non-heatable mineral board or equivalent or 24 gauge sheet metal. The floor protector is required under the stove and must extend 16" from the front, 6" from the sides and rear. It must extend under the chimney connector and 2" to either side. The floor protector may be covered with a noncombustible decorative material if desired. Without Vermont Castings Bottom Heat Shield Kit, only installations over a totally noncombustible floor are acceptable, such as unpainted concrete over earth.
Floor Protection Canada: Operate only with Vermont Castings Bottom Heat Shield Kit No.1895 in place. When installed on a combustible floor, a noncombustible floor protector is required under the heater. The floor protector must extend 480 mm (18 in.) to the front and 200 mm (8 in.) to the sides and rear.
Optional Components, U.S.: Outside Air Kit No. 1897, Mobile Home Kit No. 1898.
Most vertical installations require a ceiling heat shield and a flue collar heat shield to be installed. Consult your Owner's Manual.
MINIMUM CLEARANCES TO COMBUSTIBLE CONSTRUCTION / MINIMUM DE DÉGAGEMENT JUSQU'À LA CONSTRUCTION COMBUSTIBLE

US ENVIRONMENTAL PROTECTION AGENCY
Certified to comply with 2020 US particulate emissions standard using 2020 test protocol at 1.99 g/hr. Certified to comply with 2020 particulate emission standards for single burn rate heaters. This single burn rate wood heater is not approved for use with a flue damper. It is against Federal Regulations to operate this wood heater in a manner inconsistent with operating instructions in the Owner's Manual.

A: W/ No Shields	13 in. (330 mm)
A: W/ Wall Shield	9 in. (230 mm)*
A: W/ Rear & Connector Shields	9 in. (230 mm)*
B: W/ No Shields	24 in. (610 mm)
B: W/ Wall Shield	16 in. (405 mm)
C: W/ No Wall Shield	15 in. (380 mm)
C: W/ Wall Shield	11 in. (280 mm)
C: W/ Rear & Connector Shields	13 in. (330 mm)
D: W/ No Shields	13 in. (330 mm)
D: W/ Wall Shield	8 in. (205 mm)
D: W/ Rear & Connector Shields	13 in. (330 mm)*
E: From Rear & Sides-U.S.	6 in. (150 mm)
E: From Rear & Sides-Canada	8 in. (205 mm)
F: From Front-U.S.	16 in. (405 mm)
F: From Front-Canada	18 in. (460mm)
G: From Connector To Ceiling	18 in. (460 mm)
H: From Stove to Mantel or Trim	15 in. (380 mm)*
J: From Stove to Side Trim	12 in. (305 mm)*

CAUTION: HOT WHILE IN OPERATION - DO NOT TOUCH - KEEP CHILDREN AND CLOTHING AWAY - CONTACT MAY CAUSE SKIN BURNS - SEE NAMEPLATE AND INSTRUCTIONS. KEEP FURNISHINGS AND OTHER COMBUSTIBLE MATERIALS A CONSIDERABLE DISTANCE AWAY FROM THE APPLIANCE

ATTENTION: CHAUD LORS DU FONCTIONNEMENT - NE TOUCHEZ PAS L'APPAREIL - GARDEZ LES ENFANTS ET LES VÊTEMENTS ÉLOIGNÉS - TOUT CONTACT PEUT ENTRAÎNER DES BÛLONNÉS - TOUT CONTACT DE LA PEAU RÉPÈREZ - VOUS À LA PLAQUE SIGNALÉTIQUE ET AU MODE D'EMPLOI. GARDEZ LE MOBILIER ET LES AUTRES MATÉRIEAUX COMBUSTIBLES BIEN À L'ÉCART DE L'APPAREIL.

VERMONT CASTINGS
Made in U.S.A. of US and imported parts. / Fabriqué aux États-Unis-d'Amérique par des pièces d'origine américaine et pièces importées.
Date of Manufacture / Date de fabrication:
2019 2020 2021 JAN FEB MAR APR MAY JUN JUL AUG SEP OCT NOV DEC
Manufactured by / Fabriqué par: Hearth and Home Technologies 352 Mountain House Road, Halifax PA 17032
8390-950_R1

TABLE OF CONTENTS

1 Listing and Code Approvals

- A. Appliance Certification 4
- B. Mobile Home Approval 4
- C. Glass Specifications 4
- D. BTU & Efficiency Specifications 4

2 Special Warnings and Notes

- A. Carbon Monoxide Warnings & Considerations 5
- B. California safety information 5

3 Getting Started

- A. Design, Installation and Location 6
- B. Fire Safety 6
- C. Pre-Use Checklist 7

4 Dimensions & Clearances

- A. Appliance Dimensions 8
- B. Clearances to Combustibles 9
- C. Floor Protection 13

5 Chimneys and Venting

- A. Draft 14
- B. Chimney Connectors 14
- C. Wall Pass-throughs 14
- D. The Chimney 15

6 Mobile Home (US Only)

- A. Mobile Home Installation 20

7 Appliance Set-Up

- A. Unpack Stove 21
- B. Install Stove Legs 21

8 Operating Instructions

- A. Fuel Specifications 22
- B. General Information 22
- C. Draft Management 23
- D. Combustion Process 25
- E. Building and Maintaining a Fire 26

9 Service and Maintenance

- A. Care of the Cast Iron Surface 28
- B. Front Door Maintenance 28
- C. The Chimney System 30
- D. Service Parts List 31
- E. Warranty 34

1 Listing and Code Approvals

A. Appliance Certification

MODEL:	Aspen C3
LABORATORY:	OMNI Test Laboratories, Inc
REPORT NO.	0135WS044S / 0135WS044E
TYPE:	Solid Fuel Type Room Heaters / Space Heaters for Use with Solid Fuel
STANDARD(s):	ASTM E2515, ASTM E2780, UL 1482-2011, ULC-S627-00, CSA B415.1

Area Heated.....400 - 1,200 Square feet
 Loading..... Front
 Chimney Connector:6" (152 mm)
 Flue Exit Position Top Vent
 Primary Air Automatic Thermostat
 Glass Panels High-Temperature Ceramic
 Weight.....240 lbs. (110 kg.)

B. Mobile Home Approved

This appliance is approved for installation in mobile/manufactured homes. The structural integrity of the mobile home floor, ceiling and walls must be maintained. The appliance must be properly grounded to the frame of the mobile home, and must never be installed in a room designated for sleeping. The unit must have provisions for an outside air source when installed in a mobile home.

C. Glass Specifications

This appliance is equipped with 5mm ceramic glass. Replace glass only with 5mm ceramic glass. Please contact your dealer for replacement glass if needed.

Proposition 65 WARNING: Fuels used in gas, woodburning or oil fired appliances, and the products of combustion of such fuels, contain chemicals known to the State of California to cause cancer, birth defects and other reproductive harm.

California Health & Safety Code Sec. 25249.6



CAUTION

Check building codes prior to installation.

- Installation **MUST** comply with local, regional, state and national codes and regulations.
- Consult local building, fire officials or authorities having jurisdiction about restrictions, installation inspection, and permits.

D. BTU & Efficiency Specifications

EPA Certification Number:	
EPA Certified Emissions:	1.99 g/h
*LHV Tested Efficiency:	81.4%
**HHV tested Efficiency:	75.2%
***EPA BTU Output:	17,500
****Peak BTU/Hour Output:	35,200
Other Important Information	
Vent Size:	6 Inch (152 mm)
Firebox Size:	1.25 cu. ft.
Max. Wood Length:	18"
Ideal Wood Length:	16"
Fuel	Seasoned Cordwood (20% moisture)

**Weighted average LHV (Low Heating Value) efficiency using Douglas Fir dimensional lumber and data collected during EPA emission test.*

***Weighted average HHV (High Heating Value) efficiency using Douglas Fir dimensional lumber and data collected during EPA emission test.*

****BTU output based on EPA default efficiency and burn rate from EPA tests using Douglas Fir dimensional lumber.*

*****A peak BTU out of the appliance calculated using the maximum first hour burn rate from the High EPA Test and the BTU content of cord wood (8600) times the efficiency.*

This stove is compliant to 2020 emissions limits using crib wood.

This wood heater needs periodic inspection and repair for proper operation. It is against federal regulations to operate this wood heater in a manner inconsistent with operating instructions in this manual.

2 Special Warnings and Notes

A. Carbon Monoxide Warnings & Considerations

Carbon monoxide, referred to as CO, is a colorless, odorless gas that is produced during combustion of wood and other fuels. **CO fumes are toxic and can be fatal.**

The Aspen C3 is a natural draft system which relies on a properly designed chimney to remove CO and other combustion by-products from the stove.

Even though this stove is designed to be as safe as possible, it is important that you **install a CO detector**. This is true for oil, gas, or coal burning products as well.

CO is not specifically heavier or lighter than air. Therefore, it is best to install the detector at table top level rather than on the ceiling like a smoke detector.

CO detectors are very sensitive and may sound an alarm for fumes other than CO or CO from sources other than the stove such as car or lawn mower exhaust.

If the alarm sounds

1. Increase ventilation by opening windows or doors.
2. Make sure the stove door is closed and latched.
3. Check stove for smoking or puffing condition.
4. Check chimney for possible blockage or down-draft.
5. Check for false alarm.

SAFETY NOTICE: IF THIS APPLIANCE IS NOT PROPERLY INSTALLED, OPERATED AND MAINTAINED, A HOUSE FIRE MAY RESULT. FOR YOUR SAFETY, FOLLOW INSTALLATION DIRECTIONS. CONTACT LOCAL BUILDING OR FIRE OFFICIALS ABOUT RESTRICTIONS AND INSTALLATION INSPECTION REQUIREMENTS IN YOUR AREA.

CAUTION

WHEN THIS ROOM HEATER IS NOT PROPERLY INSTALLED, A HOUSE FIRE MAY RESULT. TO REDUCE THE RISK OF FIRE, FOLLOW THE INSTALLATION INSTRUCTIONS. CONTACT LOCAL BUILDING OR FIRE OFFICIALS ABOUT RESTRICTIONS AND INSTALLATION INSPECTION REQUIREMENTS IN YOUR AREA.

WARNING

NEVER USE GASOLINE, LANTERN FUEL, KEROSENE, CHARCOAL LIGHTER FLUID, OR SIMILAR LIQUIDS TO START OR "FRESHEN UP" A FIRE IN THIS HEATER. KEEP ALL SUCH LIQUIDS WELL AWAY FROM THE HEATER WHILE IT IS IN USE.

WARNING

NEVER CONNECT THIS UNIT TO A CHIMNEY FLUE SERVING ANOTHER APPLIANCE.

WARNING

DO NOT CONNECT TO ANY AIR DISTRIBUTION DUCT OR SYSTEM.

WARNING

THIS WOOD HEATER HAS A MANUFACTURER-SET MINIMUM LOW BURN RATE THAT MUST NOT BE ALTERED. IT IS AGAINST FEDERAL REGULATIONS TO ALTER THIS SETTING OR OTHERWISE OPERATE THIS WOOD HEATER IN A MANNER INCONSISTENT WITH OPERATING INSTRUCTIONS IN THIS MANUAL.

B. California safety information

WARNING

This product and the fuels used to operate this product (wood), and the products of combustion of such fuels, can expose you to chemicals including carbon black, which is known to the State of California to cause cancer, and carbon monoxide, which is known to the State of California to cause birth defects or other reproductive harm. For more information go to: www.P65Warnings.ca.gov

3 Getting Started

A. Design, Installation & Location Considerations

1. Appliance Location

Consideration must be given to safety, convenience, traffic flow, and the fact that the appliance will need a chimney and chimney connector. It is a good idea to plan your installation on paper, using exact measurements for clearances and floor protection, before actually beginning the installation. When installing on a combustible floor, proper floor protection must be installed. See Section 4C for details.

Maintain specified vent clearance to combustible requirements listed by the vent manufacturers instructions and all clearance to combustibles listed in this manual.

Check with your local building code agency before you begin your installation. Be sure local codes do not supersede UL specifications and always obtain the required permit so that insurance protection benefits cannot be unexpectedly canceled. If any assistance is required during installation, please contact your dealer.

We recommend that a qualified building inspector and your insurance company representative review your plans before and after the installation.

Be sure to provide a source of fresh air to the room or directly to the appliance. Make-up air is needed to replace what the chimney draws away through the appliance.

 CAUTION
DO NOT CONNECT THIS UNIT TO A CHIMNEY FLUE SERVICING ANOTHER APPLIANCE.
DO NOT CONNECT TO ANY FORCED AIR DISTRIBUTION DUCT OR SYSTEM.

B. Fire Safety

Maintain the designated clearances to combustibles. Insulation must not touch the chimney. You must maintain the designated air space around the chimney. This space around a chimney is necessary to allow natural heat removal from the area. Insulation in this space will cause a heat buildup, which may ignite wood framing.



NOTE: Clearances may only be reduced by means approved by the regulatory authority having jurisdiction.

To provide reasonable fire safety, the following should be given serious consideration:

1. Install at least one smoke detector on each floor of your home. Detectors should be located away from the heating appliance and close to sleeping areas. Follow the smoke detector manufacturer's placement and installation instructions, and be sure to maintain regularly.
2. A conveniently located Class A fire extinguisher to contend with small fires resulting from burning embers.
3. A practiced evacuation plan, consisting of at least two escape routes.
4. A plan to deal with a chimney fire as follows:

In the event of a chimney fire:

- a. Evacuate the house immediately.
- b. Notify Fire Department.
- c. Never apply water to a suspected chimney fire. Serious damage could occur.

 WARNING	
	FIRE HAZARD
	DO NOT OPERATE APPLIANCE BEFORE READING AND UNDERSTANDING THE OPERATING INSTRUCTIONS.
	FAILURE TO OPERATE PROPERLY MAY CAUSE A HOUSE FIRE.

 CAUTION
Tested and approved for use with dry, seasoned cordwood only. Do Not Burn Wet or Green Wood. Burning any other type of fuel will void your warranty.

C. Pre-Use Check List

Place the appliance in a location near the final installation and follow the procedures below:		
1		Open the appliance and remove all articles packed inside. Inspect all items for shipping damage. Notify dealer of any missing or damaged goods.
2		All safety warnings have been read and followed precisely.
3		This Owner's Manual has been read in it's entirety.
4		Floor protection requirements have been read and followed.
5		The chimney connector has been installed in accordance with the instructions herein.
6		The proper clearances from the appliance and chimney connector to combustibles have been met.
7		The masonry chimney has been cleaned and inspected by a professional, or the factory built metal chimney is installed according to the manufacturers instructions.
8		The chimney meets the minimum height requirements.
9		All labels and hang tags have been removed from the glass.
10		All plated surfaces have been wiped clean, if applicable.



WARNING



INSPECT APPLIANCE AND COMPONENTS FOR DAMAGE. DAMAGED PARTS MAY IMPAIR SAFE OPERATION.

- DO NOT INSTALL DAMAGED COMPONENTS.
 - DO NOT INSTALL INCOMPLETE COMPONENTS.
 - DO NOT INSTALL SUBSTITUTE COMPONENTS.
- REPORT DAMAGED PARTS TO DEALER.**



WARNING



FIRE RISK -

HEARTH & HOME TECHNOLOGIES DISCLAIMS ANY RESPONSIBILITY FOR, AND THE WARRANTY WILL BE VOIDED BY, THE FOLLOWING ACTIONS:

- INSTALLATION AND USE OF ANY DAMAGED APPLIANCE.
- MODIFICATION OF THE APPLIANCE.
- INSTALLATION OTHER THAN AS INSTRUCTED BY HEARTH & HOME TECHNOLOGIES.
- INSTALLATION OF PARTS OR COMPONENTS NOT SUPPLIED OR APPROVED BY HEARTH & HOME TECHNOLOGIES.
- OPERATING APPLIANCE WITHOUT THE LEGS ATTACHED.
- OPERATING APPLIANCE WITHOUT FULLY ASSEMBLING ALL COMPONENTS.
- DO NOT OVERFIRE.

OR ANY SUCH ACTION THAT MAY CAUSE A FIRE HAZARD.

4 Dimensions & Clearances

A. Appliance Dimensions

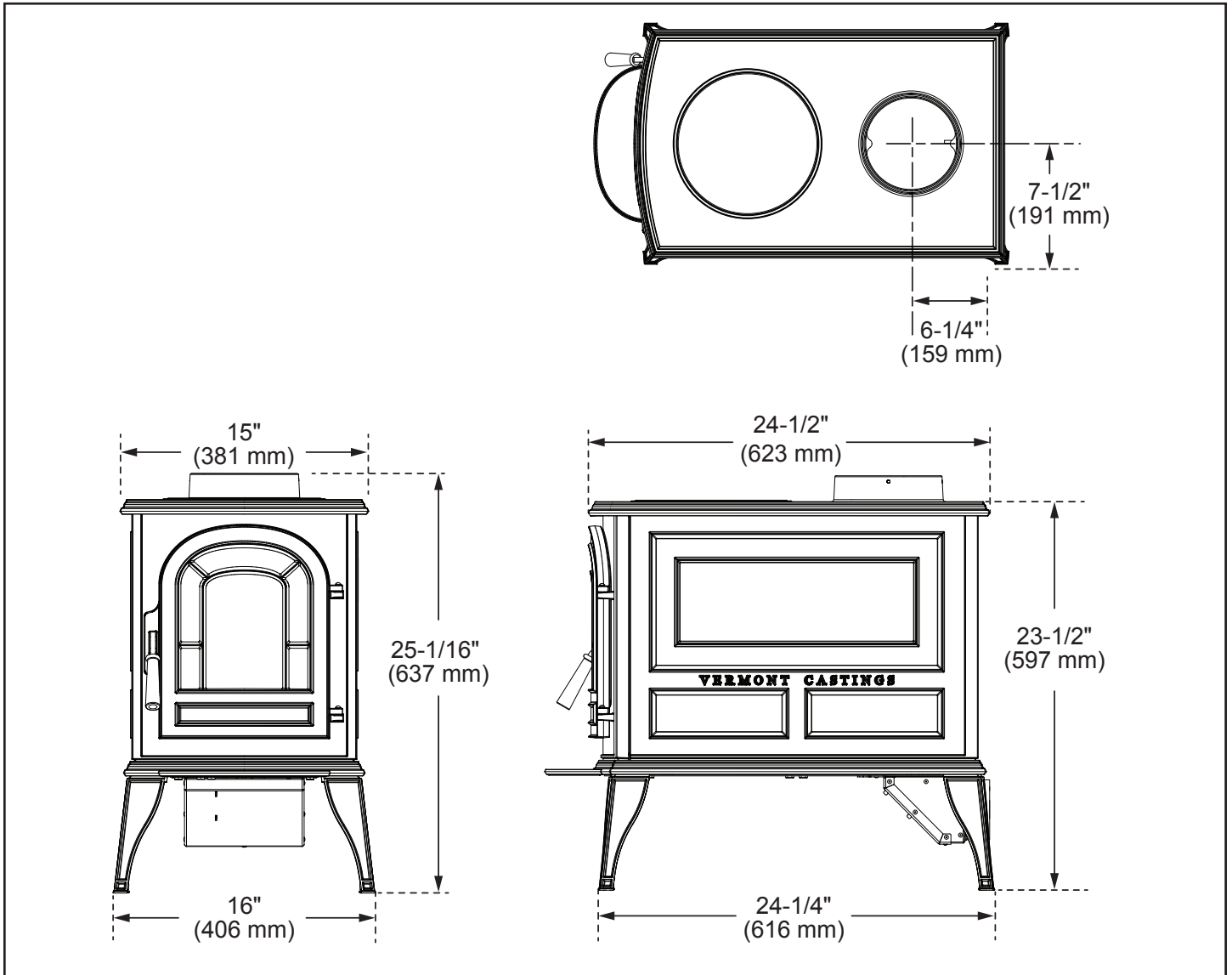

Figure 4.1 - Aspen C3 specifications.

B. Clearances To Combustibles

Use the chart below together with the diagrams in Figure 4.3 to determine the required clearance for your particular installation.

Stove clearances are measured from the top plate to the combustible surface.

Chimney connector clearances are measured from the connector surface and take into account flue collar offset.

	Unprotected Surfaces			Protected Surfaces		
	Stove Clearances					
	Stove Installed Parallel to Wall		Stove in Corner	Stove Installed Parallel to Wall		Stove in Corner
	Side	Rear	Corners	Side	Rear	Corners
No Heat Shields	(A) 24" (610 mm)	(B) 13" (330 mm)	(C) 13" (330 mm)	(D) 16" (406 mm)	(E) 9" (229 mm)	(F) 8" (203 mm)
Top Exit, Rear Heat Shield	(G) 24" (610 mm)	(H) 11" (179 mm)	(I) 13" (330 mm)	(J) 16" (406 mm)	(K) 9" (229 mm)	(L) 8" (203 mm)
Top Exit, Rear H.S., Single Wall Connector Shields ^{1,2}	(M) 24" (610 mm)	(O) 9" (229 mm)	(P) 13" (330 mm)	(Q) 16" (406 mm)	(R) 9" (229 mm)	(S) 8" (203 mm)
Top Exit, Rear H.S., Double-Wall Connector Shields ^{1,3}	(M) 24" (610 mm)	(O) 7" (178 mm)	(P) 13" (330 mm)	(Q) 16" (406 mm)	(R) 7" (178 mm)	(S) 8" (203 mm)
Chimney Connector	Unprotected Surface / Vertical			Protected Surface / Vertical		
No Heat Shield	15" (381 mm)			11" (279 mm)		
Using Heat Shields ²	13" (330 mm)			6" (152 mm)		
Double-wall connector ³	6" (152 mm)			6" (152 mm)		
	Unprotected Surface / Horizontal			Protected Surface / Horizontal		
Single Wall Connector	18" (457 mm)			11" (279 mm)		
Double Wall Connector	6" (152 mm)			6" (152 mm)		
Front Clearance to Combustibles			All Installations: 48" (1219 mm)			
<p>** A distance of 48" must be maintained between the stove and movable combustible items such as drying clothes, furniture, firewood, etc.</p> <p>¹ When a rear heat shield is installed on a top exit stove, the shield insert must be attached to the shield so the area behind the flue collar on the stove is protected.</p> <p>² Chimney connector heat shields must extend exactly 24" (610 mm) above the top of the stove. No shielding can be used on the connector above 24" (610 mm). The unshielded chimney connector above the 24" (610 mm) point must be 13" (330 mm) from an unprotected wall.</p> <p>³ In top exit installations, this clearance requires the use of the rear stove heat shield with the flue collar cover plate installed.</p>						

Figure 4.2

Any clearance highlighted in Red is TBD. Use "No heat Shields" clearances for any installation at this time.

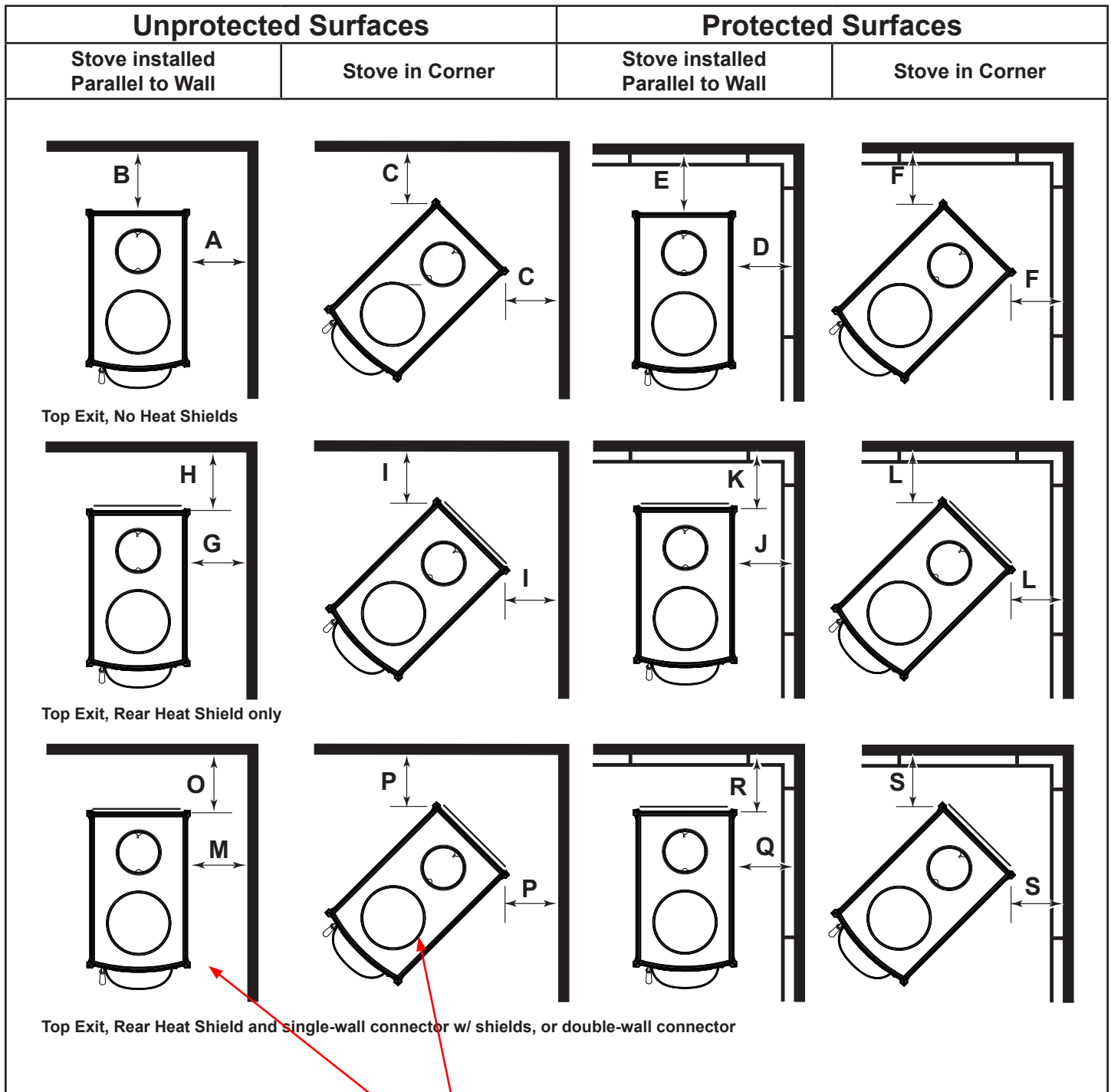

Figure 4.3

Any clearance highlighted in Red is TBD. Use "No heat Shields" clearances for installation at this time.

Making changes if not testing with connector shields or heat shields

Wall Shields:

Wall shields should be constructed of 24 gauge or heavier sheet metal, or another noncombustible material such as 1/2" (13 mm) insulation board or common brick "laid on flat," with the 3-1/2" (90mm) side down.

Shields must be spaced out from the combustible surface 1" (25 mm) on noncombustible spacers. The spacers should not be directly behind the stove or chimney connector.

Air must be able to flow between the wall and the shield. At least 50% of the bottom 1" (25 mm) of the shield should be open and the shield must be open at the top.

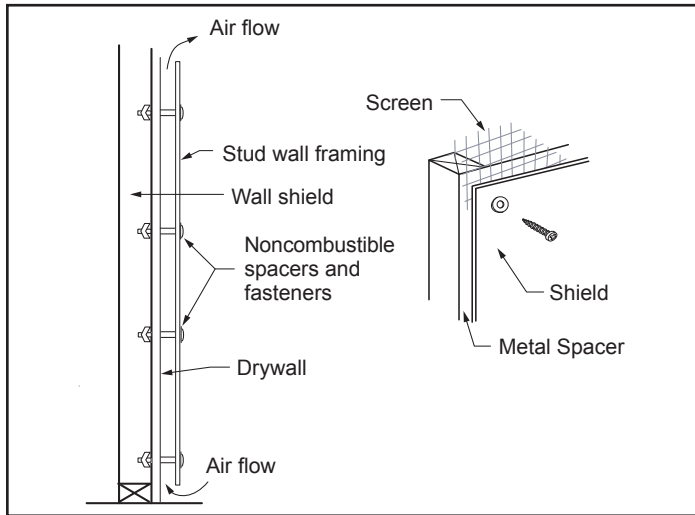

Figure 4.4 - Approved wall shield construction

The following examples of wall shield construction illustrate common designs used to safely achieve reduced clearances to combustible wall materials.

Parallel installation, vertical chimney connector, two wall shields. Figure 4.5: Reduced clearances for both rear and side walls. Wall shields may meet at corner if desired. Shielding for connector is centered behind connector.

Parallel installation with rear wall pass-through, two wall shields. Figure 4.6: Reduced clearances for both rear and side walls. Wall shields may meet at corner if desired. Shielding for connector is centered behind connector. Wall pass-through must comply with codes.

Corner installation, vertical chimney connector, two wall shields. Figure 4.7: Reduced side clearances. Wall shields **MUST** meet at corner.

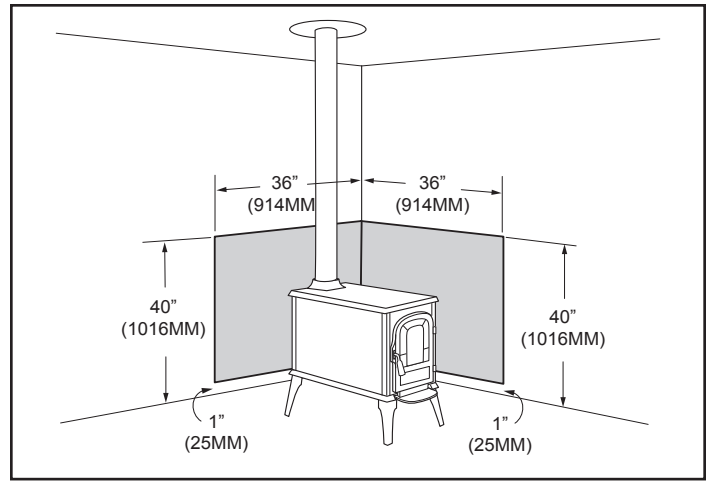

Figure 4.5 - Parallel installation, vertical chimney connector, two wall shields.

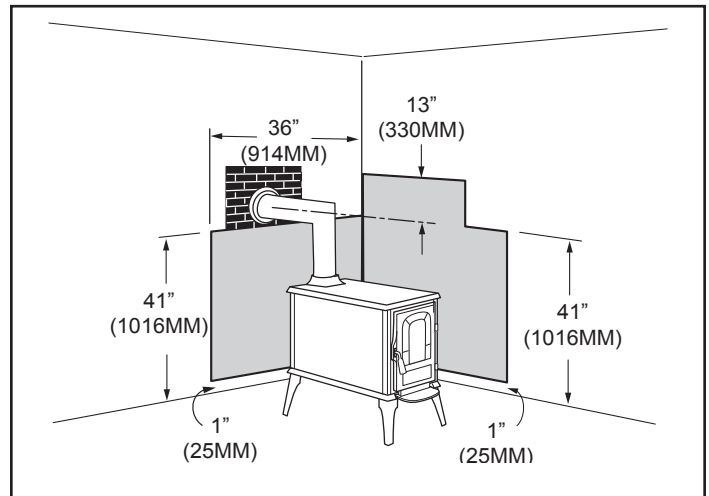

Figure 4.6 - Parallel installation with rear wall pass-through, two wall shields.

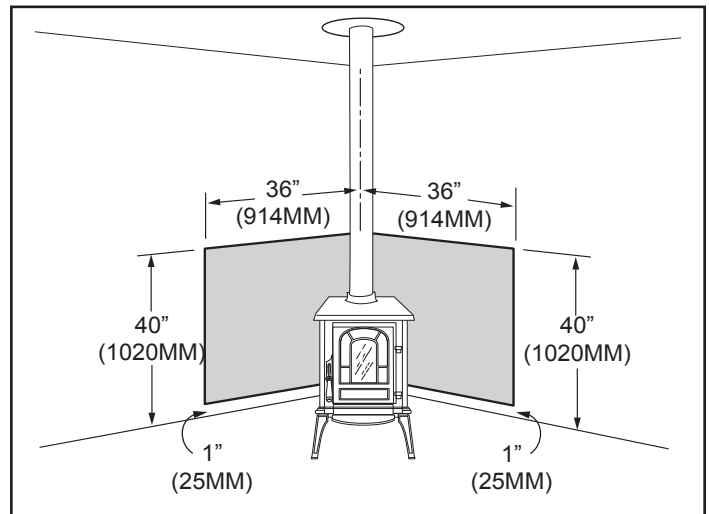

Figure 4.7 - Corner installation, vertical chimney connector, two wall shields.

Fireplace Clearances:

A fireplace installation requires special clearance between the side of the stove and the right and left walls, the side of the stove and the decorative side trim on the fireplace face, and the top of the stove and the mantel.

Maximum Mantel depth (A, Figure 4.8) of a combustible mantel is 9" (230 mm). At that depth, the clearance to the stove top (B) must be a minimum of 22-1/2" (572 mm).

Top Trim (C) protruding less than 1-1/2" (38 mm) from the face of the fireplace must be a minimum of 12" (305 mm) from the stove top. This clearance may not be reduced by shielding.

For every 1-1/2" (38 mm) increment that the trim or mantel extends in depth, the clearance from the stove top must also be increased by 1-1/2" (38 mm).

Side Trim must have a minimum clearance of 8" (203 mm), measured from the stove's top edge. (D, Figure 4.9)

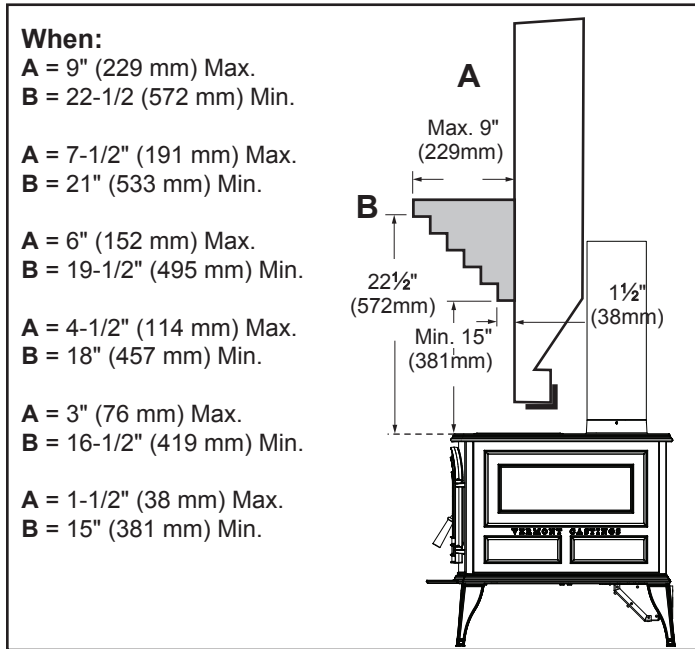

Figure 4.8 - Mantel and trim clearances.

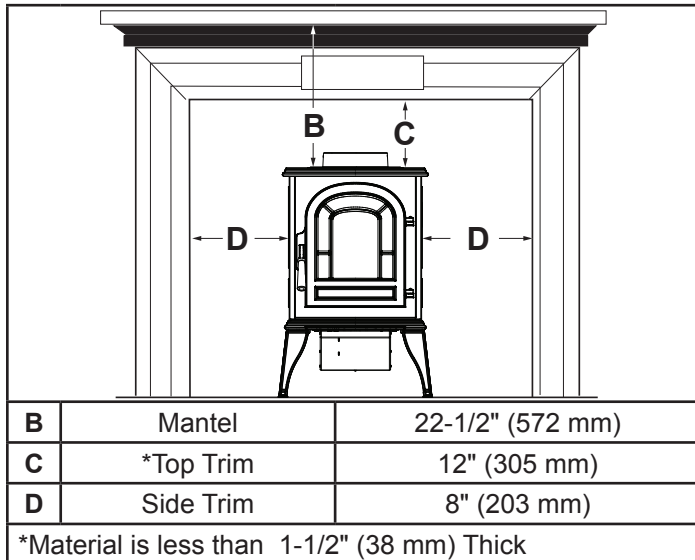

Figure 4.9 - Mantel and trim clearances.

Alcove Clearances:

The Aspen C3 is approved for installation into an alcove constructed to maintain the clearances diagrammed in Figure 4.10.

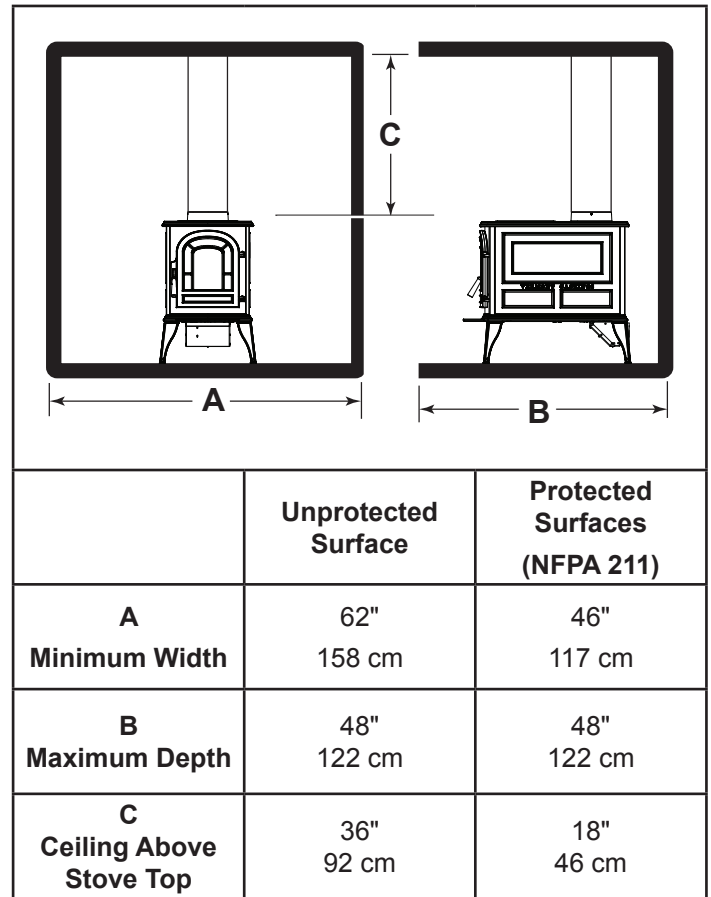

Figure 4.10 - Alcove Specifications.

C. Floor Protection Requirements

The floor area directly under and around the stove will require protection from stray sparks or embers that may escape the firebox.

Use a noncombustible floor protector such as 1/4" non-asbestos mineral board or equivalent, or 24 gauge sheet metal. The floor protector may be covered with a noncombustible decorative material if desired. Do not obstruct the space under the heater.

Protection requirements vary somewhat between the United States and Canada as follows:

U.S. Installations: The floor protector is required under the stove and must extend at least 16" from the front of the stove (B, Figure 4.11), and at least 6" from the sides and rear (A, Figure 4.11). It must also extend under the chimney connector and 2" to either side. (C, Figure 4.11)

In Canada: A noncombustible floor protector is required under the heater. The floor protector must extend 18" (457 mm) to the front (B, Figure 4.11) and 8" (203 mm) from the sides and rear. (A, Figure 4.11)

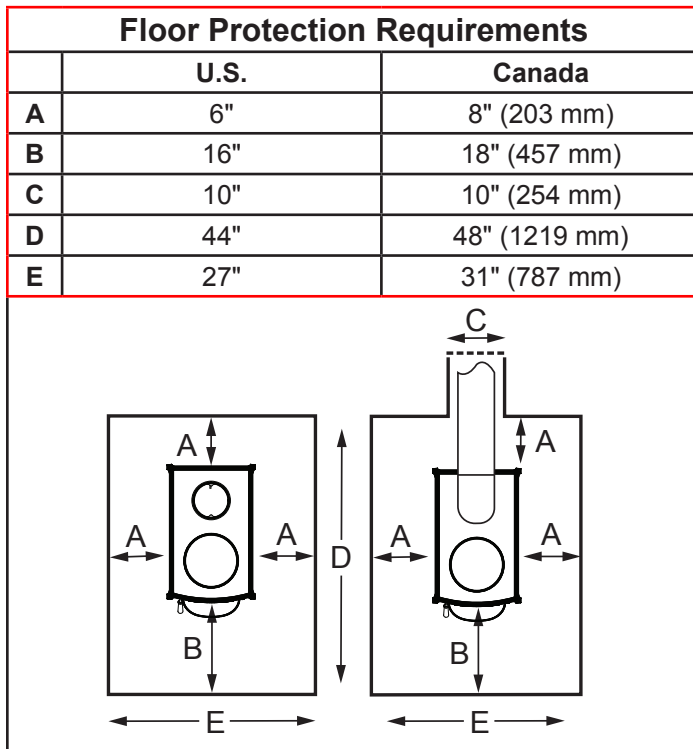

Figure 4.11 - These dimensions are minimum requirements only. Use greater dimensions whenever possible.

Fireplace Hearth Protection:

Do not assume that your fireplace hearth is completely noncombustible. Many fireplace hearths do not satisfy the "completely noncombustible" requirement because the brick or concrete in front of the fireplace opening is supported by heavy wood framing. Because heat is readily conducted by brick or concrete, it can easily pass through to the wood. As a result, such fireplace hearths can be a fire hazard and are considered a combustible floor.

For all fireplace installations, follow the floor protection guidelines described above.

Keep in mind that many raised hearths will extend less than the required clearance from the front of the heater when it is installed. In such cases, sufficient floor protection as described above must be added in front of the hearth to satisfy the minimum floor protector requirement from the front of the stove: 16" (406 mm) from the front in the United States and 18" (457 mm) from the front in Canada.

Hearth rugs do not satisfy the requirements for floor protection as they are only fire-retardant, not fire proof.

Fireplace installations also have special clearance requirements to the side walls, side decorative trim and fireplace mantel. Refer to the information on fireplace and mantel trim shields in this section.

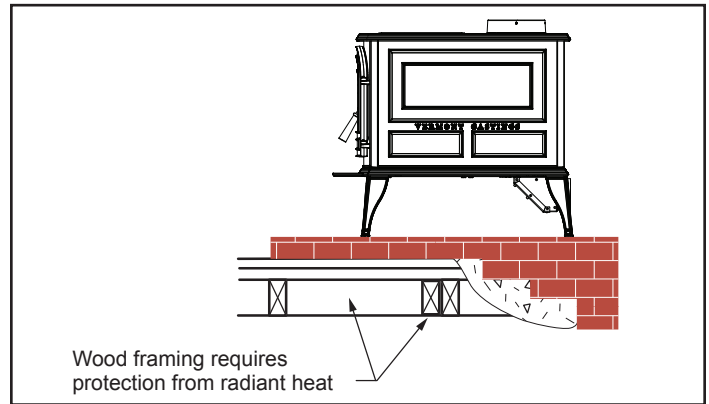

Figure 4.12 - Supporting timbers under fireplace hearths are considered to be combustible.

A. Draft

Draft is widely misunderstood. It is important that you, the stove operator, realize that draft is a variable *effect*, not a given quantity. Stoves and chimneys do not *have* draft, yet draft is the key to your stove's performance.

Draft is a *force*, produced by an operating stove and the chimney to which it is attached. It is created by hot gases rising up the chimney, creating a pressure difference between the inside of your home and the outside air. It continually moves fresh combustion air into the stove, and hot exhaust gases out of the stove; without this constant flow, the fire will go out.

Other factors, such as barometric pressure, winds, the airtightness of the home, the total inside chimney volume, chimney height and the presence of venting devices such as exhaust fans also play a role in maintaining an adequate draft. Low barometric pressures, super insulated homes and exhaust fans can reduce draft; winds can play havoc with draft; and too large or too small a chimney volume can cause reduced draft due to the excessive cooling or not enough room to vent exhaust gases. Introducing outside air directly to the stove may help remedy a low draft problem. Some signs of inadequate draft are smoking, odor, difficulty in maintaining the fire, and low heat output. Overdraft can be caused by a very tall chimney even if it is the recommended size, and can cause overfiring of your stove. Signs of an overdraft include rapid fuel consumption, inability to slow the fire, and parts of the stove or chimney connector glowing red. It is important that you follow the chimney guidelines in this manual, including size, type, and height to avoid draft problems.

When installed and operated according to this manual, the Aspen C3 will produce enough hot gases to keep the chimney warm so that adequate draft is maintained throughout the burn cycle.

B. Chimney Connectors

In general, following these guidelines will ensure compliance with all national and provincial codes; prior to beginning your installation, check with your local building code official to check on additional local regulations which may influence the design and placement of your venting system.

The Vermont Castings Aspen C3 may be installed with a minimum (.6mm) 24 gauge chimney connector pipe. The size of the connector should correspond to the size of the flue collar opening. Do not use makeshift compromises. No part of the chimney connector may pass through an attic or roof space, closet or other concealed space, or through a floor or ceiling. Whenever possible, avoid passing the connector through a combustible wall; if you must, use an approved wall pass-through, described later in this section.

Assemble the connector beginning at the flue collar, with the crimped ends pointing towards the stove (to keep debris or residue inside the system). Each joint, including the one to the stove's flue collar and the one to the chimney itself should be secured with at least three sheet metal screws. Screws may be a maximum of 3 inches apart. A 1-1/4" (30mm) overlap is required at each joint, including the flue collar attachment. No more than two 90° elbows should be used, and the total length of connector should not exceed 10 feet (3m). All horizontal runs of connector must have a minimum upward slope of 1/4" (6mm) per foot (20mm per meter).

The chimney connector diameter should correspond to the size of the flue collar opening. Do not use makeshift compromises. No part of the chimney connector may pass through an attic or roof cemented in place with refractory cement.

C. Wall Pass-throughs

Depending on your local building codes, and the pertinent provincial or national codes, there are several choices for passing the chimney connector safely through a wall. Before beginning your installation, contact local officials, and also the chimney connector and chimney manufacturer for specific requirements.

Canada. Three methods are approved by the Canadian Standards Association. Figure 5.10 shows one method requiring an 18" (450mm) air space between the connector and the wall. It allows use of one or two covers as described in the diagram. The two other methods are described in detail in the current issue of CAN/CSA B365, the national standard.

United States In the U.S., the national code is NFPA 211. While many localities adopt this standard, be sure to check with local authorities before beginning your installation.

The NFPA (National Fire Protection Agency) permits four methods for passing through a combustible wall. A commonly used method to pass through a wall directly to a masonry chimney is to clear a minimum 12" (300mm) around the entire chimney connector, and fill it with brick masonry which is at least 3.5" (90mm) thick. A fireclay liner, minimum 3/8" (9mm) wall thickness must run through the brick wall to the chimney liner (but not beyond the inner surface of the liner). It must be cemented in place with refractory cement. For details on the other three options, refer to the most recent edition of the NFPA 211 code.

D. The Chimney

SAFETY NOTICE: IF YOUR STOVE IS NOT PROPERLY INSTALLED, OPERATED AND MAINTAINED, A HOUSE FIRE MAY RESULT. FOR SAFETY, FOLLOW ALL INSTALLATION, OPERATION AND MAINTENANCE DIRECTIONS. CONTACT LOCAL BUILDING OFFICIALS ABOUT RESTRICTIONS AND INSTALLATION INSPECTION REQUIREMENTS IN YOUR AREA.

Before you begin an installation, review your plans to be certain that:

- Your stove and chimney connector will be far enough from combustible material to meet all clearance requirements.
- The floor protector is large enough and is constructed properly to meet all requirements.
- You have all necessary permits from local authorities.

Your local building official is the final authority for approving your installation as safe and determining that it meets local and state codes.

The metal label permanently attached to the back of the stove indicates that the Aspen C3 has been tested to current UL and ULC standards. Clearance and installation information is also printed on the label. Local authorities generally will accept the label as evidence that, when the stove is installed according to the information on the label and in this manual, the installation meets codes and can be approved. Codes, however, vary in different areas. Before starting the installation, review your plans with the local building authority. Your local dealer can provide any additional information needed.

For any unresolved questions about installation, refer to the National Fire Protection Association's publication ANSI/NFPA 211-1988 Standard for Chimneys, Fireplaces, Vents and Solid Fuel Burning Appliances. In Canada, the equivalent publication is CSA CAN-B365, Installation Code for Solid Fuel Burning Appliances and Equipment. These standards are the bases for many national codes. They are nationally recognized and are accepted by most local authorities. Your local dealer or your local building official may have a copy of these regulations.

IMPORTANT: Failure to follow these installation instructions may result in a dangerous situation, including a chimney or house fire. Follow all instructions exactly and do not allow makeshift compromises to endanger property and personal safety.

Chimneys:

Your stove must be connected either to a sound masonry chimney that meets local codes, to a relined masonry chimney that meets local codes, or to an approved prefabricated metal chimney. Whichever of those types you use, the chimney and chimney connector must be in good condition and kept clean.

If you use an existing masonry chimney, it must be inspected to ensure safe condition before the stove is installed. Your local professional chimney sweep, building inspector, or fire department official will be able to make the inspection or direct you to someone who can.

The chimney should extend at least 3' (914 mm) above the highest point where it passes through a roof, and at least 2' (610 mm) higher than any portion of a building within 10' (3 m).

To assure proper draft and good performance, any chimney used with this stove should extend at least 16' (4.9 m) above the flue collar of the stove.

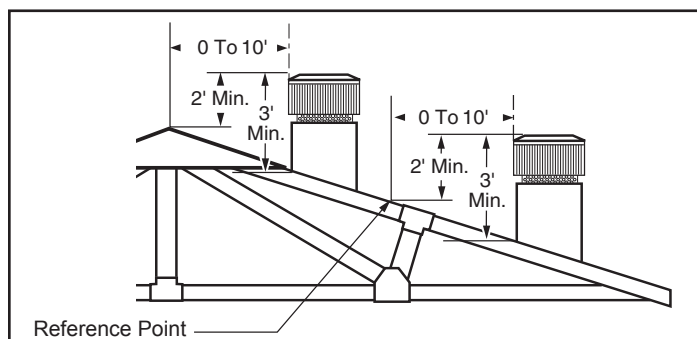

Figure 5.1 - The 2'-3'-10' Chimney Rule.

Masonry Chimneys:

An existing masonry chimney must be inspected to confirm that it has a lining. Do not use an unlined chimney. The chimney also should be examined for cracks, loose mortar, other signs of deterioration, and blockage. Repair any defects before the chimney is used with your stove.

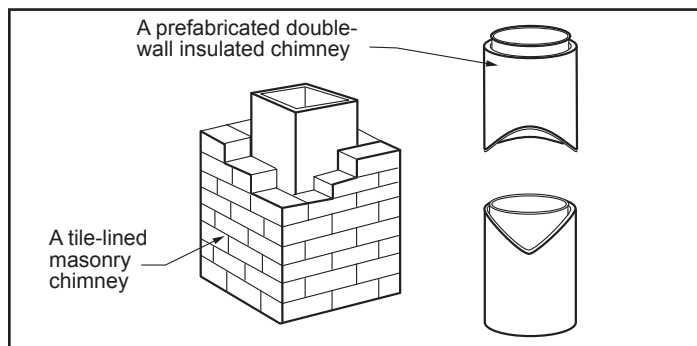

Figure 5.2 - Standard Chimney Types

Masonry Chimneys, cont'd.:

- Unused openings in an existing masonry chimney must be sealed with masonry to the thickness of the chimney wall, and the chimney liner should be repaired. Openings sealed with pie plates or wallpaper are a hazard and should be sealed with mortar or refractory cement. In the event of a chimney fire, flames and smoke may be forced out of these unused thimbles.
- The chimney should be thoroughly cleaned before use.
- A newly-built masonry chimney must conform to the standards of local building code, or, in the absence of a local code, to a recognized national code. Masonry chimneys must be lined, either with code-approved masonry or pre-cast refractory tiles, stainless steel pipe, or a code-approved, "poured-in-place" liner. The chimney clean-out door must seal tightly to ensure a good draft.

Prefabricated Chimneys:

A prefabricated metal chimney must be one that is tested and listed for use with solid-fuel burning appliances to the High-Temperature (H.T.) Chimney Standard UL-103-1985 (2100°F.) for the United States, and High Temperature (650°C) Standard ULC S-629 for Canada.

Chimney Size:

This stove is approved for venting into a masonry chimney with a nominal flue size of 8" x 8" (203 x 203 mm), and into a round flue size of 8" (203 mm) or 6" (152 mm).

It may be vented into larger chimneys as well. However, chimneys with liners larger than 8" x 12" (203 x 305 mm) may experience rapid cooling of smoke and reduction in draft, especially if they are located outside the home. Such large chimneys may need to be insulated or have the flue relined for proper stove performance.

Ask your dealer about components available for connecting the stove to a steel chimney liner.

Do not connect this unit to a chimney flue serving another appliance.

NOTE: Do not vent this stove into a factory-built (zero-clearance) fireplace. This stove has not been tested and listed for that type of installation. Factory-built fireplaces and their chimneys are specifically designed as a unit for use as fireplaces. It may void the listing or be hazardous to adapt them for any other use.

Do not connect the STOVE to any air distribution duct or system.

Chimney Connector Guidelines:

A chimney connector is the double-wall or single-wall pipe that connects the stove to the chimney. The chimney itself is a masonry or prefabricated structure that encloses the flue. Chimney connectors are used only to make the connection from the stove to the chimney. They are for interior use only.

Double-wall connectors must be tested and listed for use with solid-fuel burning appliances. Single-wall connectors should be made of 24 gauge or heavier steel, and should be 6" (152 mm) in diameter. Do not use galvanized chimney connector; it cannot withstand the high temperatures that can be reached by smoke and exhaust gases, and may release toxic fumes under high heat.

If possible, do not pass the chimney connector through a combustible wall or ceiling. If passage through a combustible wall is unavoidable, refer to the recommendations in the section following on Wall Pass-throughs. Do not pass the connector through an attic, a closet or any similar concealed space. The whole chimney connector should be exposed and accessible for inspection and cleaning.

Install the single wall chimney connector not less than 18" (457 mm) from the ceiling. Keep it as short and direct as possible, with no more than two 90 degree turns. If possible, use 45° elbows. Slope horizontal runs of connectors upward 1/4" per foot (20 mm per meter) going from the stove toward the chimney. The recommended maximum length of a horizontal run is 3' (914 mm), and the total length of chimney connector should be no longer than 8' (2.5 meters).

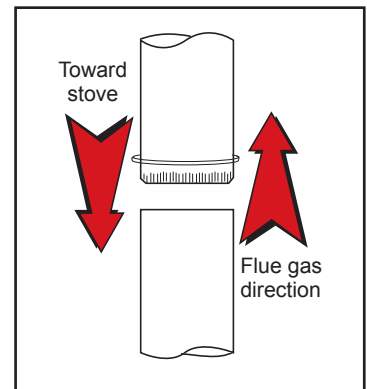

Figure 5.3 - Chimney connector.

In cathedral ceiling installations, extend the prefabricated chimney downward to within 8 feet (2.4m) of the stove.

SAFETY NOTE: Always wear gloves and protective eye-wear when drilling, cutting or joining chimney connector sections .

Double-wall Chimney Connectors:

The Aspen C3 is approved for installation in the U.S. and Canada with double-wall chimney connectors that have been tested and listed for use with solid-fuel burning appliances by a recognized testing laboratory.

Follow the instructions for assembling and installing double-wall connectors provided by the manufacturer of the double-wall chimney. To ease assembly and help assure safety, use chimney components manufactured by a single source.

NOTE: For installations using double-wall connectors, minimum clearances must conform to those listed in the clearance chart in Section B - Figure 4.2.

Single-wall Chimney Connectors:

- Beginning at the flue collar of the stove, assemble the chimney connector. Insert the first crimped end into the stove's flue collar, and keep each crimped end pointing toward the stove. Using the holes in the flue collar as guides, drill 1/8" (3 mm) holes in the bottom of the first section of chimney connector and secure it to the flue collar with three #10 x 1/2" sheet metal screws.
- Secure each joint between sections of chimney connector, including telescoping joints, with at least three sheet metal screws. The pre-drilled holes in the top of each section of chimney connector serve as guides when you drill 1/8" (3 mm) holes in the bottom of the next section.
- Secure the chimney connector to the chimney. Instructions for various installations follow.
- Be sure the installed stove and chimney connector are correct distances from nearby combustible material.

NOTE: Special slip pipes and thimble sleeves that form telescoping joints between sections of chimney connector are available to simplify assembly. Slip pipes eliminate the need to cut individual connector sections. Consult your local dealer about these special connector sections.

Securing the Single-wall Connector to a Prefabricated Chimney:

Follow the installation instructions of the chimney manufacturer exactly.

Special adapters are available from your local dealer to make the connection between the prefabricated chimney and the chimney connector. The top of such adapters attach directly to the chimney or to the chimney's ceiling support package. The bottom of the adapter is secured to the chimney connector.

The adapter forms a union between the chimney and chimney connector that ensures any soot or creosote falling from the inner walls of the chimney will stay inside the chimney connector.

Securing the Single-wall Connector to a Masonry Chimney:

The Aspen C3 may be connected to either a freestanding masonry chimney or to a fireplace masonry chimney.

Freestanding Installations

If the chimney connector must pass through a combustible wall to reach the chimney, follow the recommendations for Wall Pass-Through construction in Figures 5.6 thru 5.9 from this section.

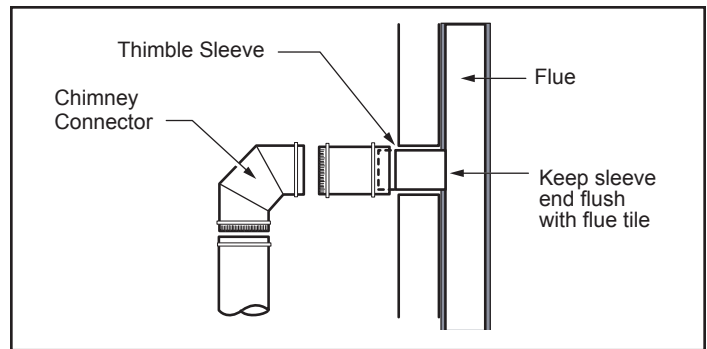

Figure 5.4 - The thimble, made of either ceramic or metal, must be cemented securely in place.

The opening through the chimney wall to the flue - the "breach" - must be lined with a ceramic or metal thimble which is securely cemented in place.

A metal pipe section called the "thimble sleeve," slightly smaller in diameter than standard connector and the thimbles, will allow the removal of the chimney connector system for inspection and cleaning. Thimble sleeves are available from your local dealer.

To install a thimble sleeve, slide it into the breach until it is flush with the inner flue wall. Be sure that it does not extend into the flue passage where it could interfere with the draft.

The thimble sleeve should protrude 1-2" (25-50 mm) into the room. Use furnace cement and thin gasketing to seal the sleeve in place in the thimble. Secure the chimney connector to the outer end of the sleeve with sheet metal screws.

Connection Above the Fireplace:

In this installation, the chimney connector enters the fireplace flue through a thimble located above the fireplace. The liner of the fireplace chimney should extend at least to the point at which the chimney connector enters the chimney. Follow all the guidelines for installing a chimney connector into a freestanding masonry chimney, and pay special attention to these additional points:

- Check the stove and chimney connector clearances to combustible mantel and trim materials. If necessary, use a combination of mantel, trim, and connector heat shields to provide the required clearances.
- Double-check connector clearance to the ceiling.
- The fireplace damper must be closed and sealed to prevent room air from being drawn up the flue which could reduce performance. However, it must be possible to reopen the damper to inspect or clean the chimney.

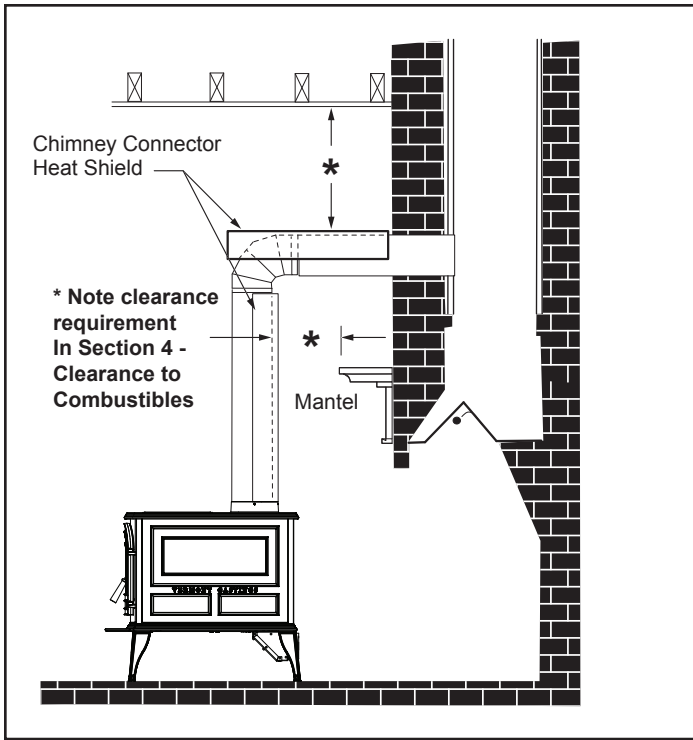

Figure 5.4 - If the clearance between the chimney connector and either the ceiling or the mantel is inadequate, a protective heat shield is required.

Connection Through the Fireplace:

If your fireplace opening height is at least 21-1/2" (546 mm), you may install a stove through the opening using a "positive connection" kit available from your local dealer. These kits provide a secure connection between the stove flue collar and the chimney flue.

Confirm that the stove location is within the required clearance specifications for the mantel and surrounding fireplace trim. Refer to Section 4 - Wall Shields.

Floor protection requirements also apply to fireplace installations. Refer to Section 4 - Floor Protection.

Wall Pass-throughs:

Whenever possible, design the installation so that the connector does not pass through a combustible wall. If you must include a wall pass-through in your installation, check with your building inspector before you begin. Also check with the chimney connector manufacturer for any specific requirements.

Consult with your dealer regarding special connection components available for use as wall pass-throughs. Use only parts that have been tested and listed for use as a wall pass-through.

U.S. Requirements:

The National Fire Protection Association (NFPA) has established guidelines for use in the United States for passing chimney connectors through combustible walls. Many building code inspectors follow these guidelines.

Figure 5.5 shows one NFPA-approved method. All combustible material in the wall is cut away to provide 12" (305 mm) clearance to the connector. Brick and mortar are used to enclose the clearance area.

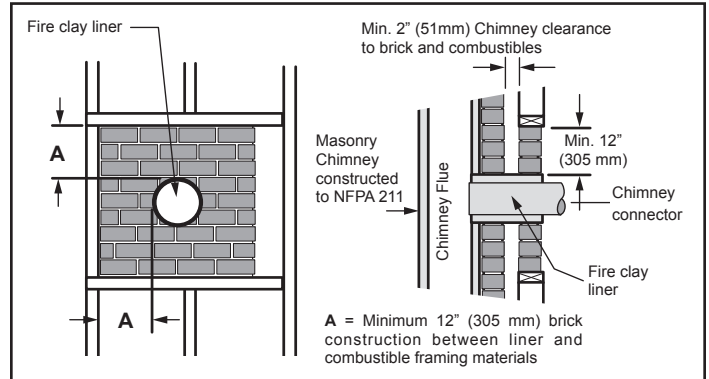

Figure 5.5 - Masonry Wall Pass-through with single wall chimney connector.

Alternate methods approved by the NFPA:

- Using a section of double-wall chimney with a 9" (229 mm) clearance to combustibles. (Figure 5.6)
- Placing a chimney connector pipe inside a steel double-wall ventilated thimble, which is then separated from combustibles by 6" (152 mm) of fiberglass insulating material. (Figure 5.7)
- Placing a chimney connector pipe inside a section of 9" (229 mm) diameter, solid-insulated, factory-built chimney, with two inches of air space between the chimney section and combustibles. (Figure 5.8)

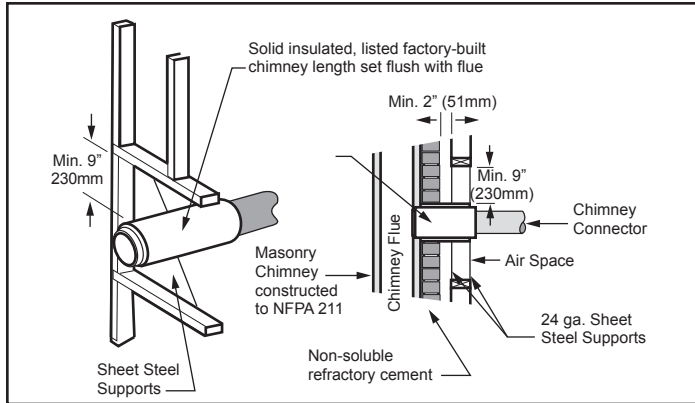

Figure 5.6 - Wall Pass-through using factory-built insulated chimney section.

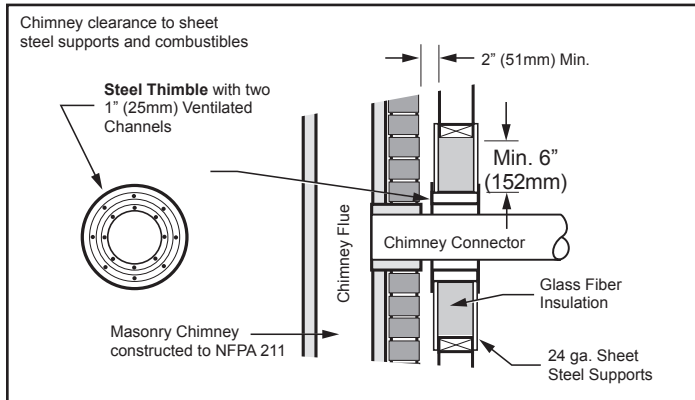

Figure 5.7 - Wall Pass-through using single wall chimney connector with a ventilated steel thimble.

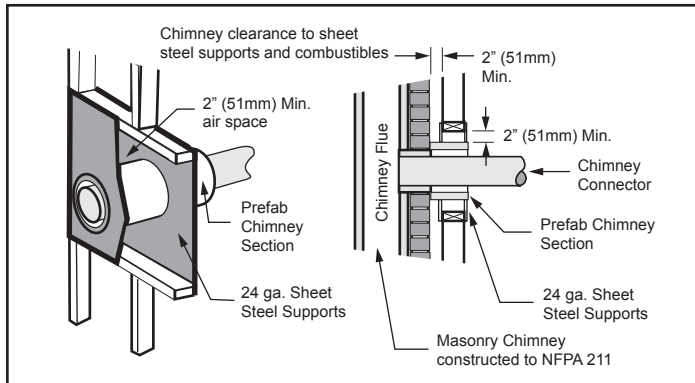

Figure 5.8 - Wall Pass-through with ventilated steel thimble.

Canadian Requirements:

In Canada, the Canadian Standards Association has established specific guidelines regarding wall pass-through design. Figure 5.9 shows one approved method in which all combustible material in the wall is cut away to provide the required 18" (457 mm) clearance around the connector. The resulting space must remain empty. A flush-mounted sheet metal cover may be used on one side only. If covers must be used on both sides, each cover must be mounted on noncombustible spacers at least 1" (25 mm) clear of the wall. Your local dealer or your local building inspector can provide details of other approved methods of passing a chimney connector through a combustible wall.

In Canada, this type of installation must conform to CAN/CSA-B365, Installation Code for Solid Fuel Burning Appliances and Equipment.

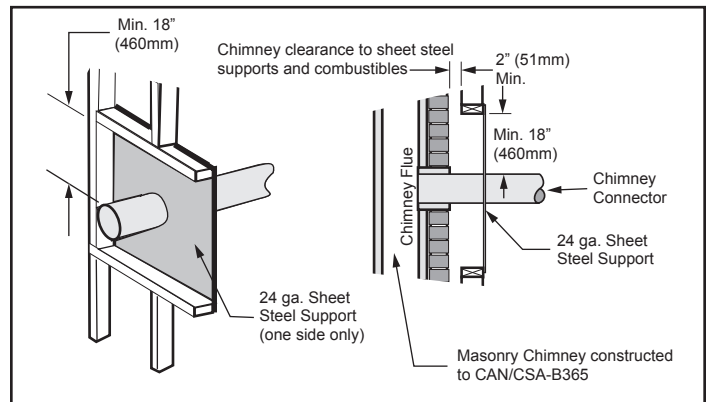

Figure 5.9 - CSA approved Wall Pass-through.

6 Mobile Home

A. Mobile Home Installation

Mobile home approval - U.S. only.

DO NOT INSTALL IN A MOBILE HOME IN CANADA.

The Aspen C3 is approved for use in manufactured (mobile) homes when installed with the optional Mobile Home Bracket Kit #1-00-277 in accordance with the instructions provided with that kit and any local codes. This approval applies only in the United States.

In addition to the standard installation requirements described in this manual, the following guidelines apply to mobile home installations:

1. The stove must be permanently secured to the floor using mobile home brackets supplied along with screws or lag bolts (not supplied). Note: The Mobile Home Brackets get installed between the leg leveler and cast leg, Figure 6.1

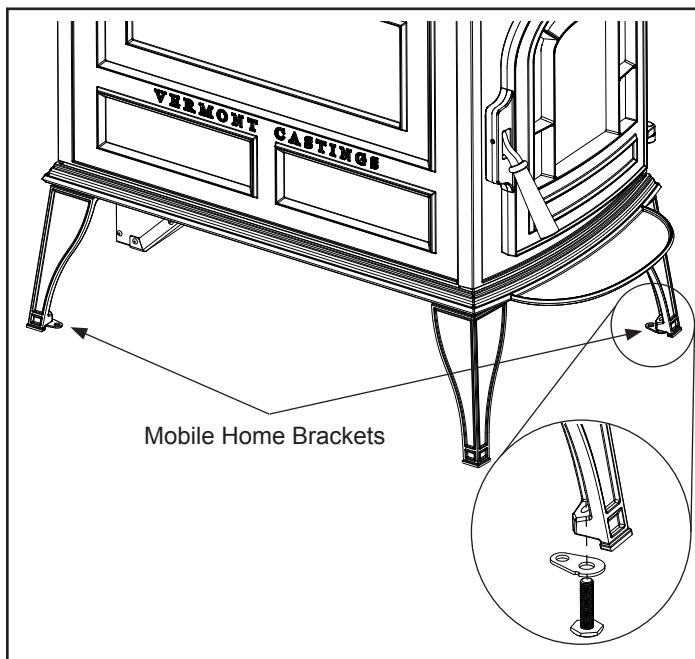



Figure 6.1

2. The stove must have a permanent connection to the outside to supply combustion air.
3. A listed chimney system, including roof thimble, spark arrestor, chimney supports, roof flashing and any other components suitable for use in mobile homes must be used. The chimney system must comply with the standard for Chimneys Factory-Built Residential Type and Building Heating Appliances UL 103.
4. The chimney must be attached directly to the stove and must extend at least 3' (914mm) above the part of the roof through which it passes. The top of the chimney must extend at least 2' (610 mm) above the highest point of any part of the mobile home structure within 10' (3 m) of the chimney.

5. If the chimney exits the mobile home through a wall at a point 7 feet or less above the ground level on which the mobile home is located, a guard or other noncombustible enclosure must be fitted at the point of exit and extend up to a height of 7' (2.1 m). Any openings in this guard must be smaller than 3/4" (19 mm).
6. Check all local building codes, specifically those related to mobile homes. Other requirements may be applicable to chimney system removal for transportation of the mobile home.

 WARNING
INSTALLATION MUST COMPLY WITH MANUFACTURED HOME AND SAFETY STANDARD (HUD), CFR 3280, PART 24.

 WARNING
NEVER INSTALL IN A ROOM INTENDED FOR SLEEPING.

 CAUTION
MAINTAIN STRUCTURAL INTEGRITY OF MOBILE HOME:
<ul style="list-style-type: none">• FLOOR, WALL, CEILING AND/OR ROOF. DO NOT CUT THROUGH:• FLOOR JOIST, WALL STUDS, OR CEILING TRUSSES.• ANY SUPPORTING MATERIAL THAT WOULD AFFECT THE STRUCTURAL INTEGRITY.

 CAUTION
NEVER DRAW OUTSIDE COMBUSTION AIR FROM:
<ul style="list-style-type: none">• WALL, FLOOR OR CEILING CAVITY.• ENCLOSED SPACE SUCH AS AN ATTIC OR GARAGE

7 Appliance Set-Up

You will need the following tools to assemble the Aspen C3:

- Safety Glasses & Gloves
- Power Drill w/ 1/8" (3mm) bit
- 9/16" Open End Wrench
- Stub Handle Phillips Screwdriver

A. Unpack the Stove

1. Remove (4) 3/8 X 2" lag screws from shipping brackets.
2. Inspect the stove and contents for shipping damage or missing parts. Immediately notify your dealer of any damage. Do not install this stove if any damage is evident or any parts are missing.

Hardware Bag contents:

- Owner's Registration Card

B. Install Stove Legs

Leg installation will be accomplished most easily with the help of an assistant who can tilt the stove onto its side while you attach the legs.

1. With your assistant holding the stove up on its side, remove (2) shipping brackets by removing the 3/8" Hex bolts and washers. **Note: DO NOT** discard these bolts and washers as they will be re-used to install the legs.
2. Place legs at each corner of the unit and install the 3/8" hex head bolts and washer previously removed. The shoulder of the legs should seat within the locator bosses cast into the stove bottom at each corner, Figure 7.1. Tighten the bolts with the wrench. **CAUTION: Overtightening can strip tapped threads.**
3. With your assistant, lift the stove up onto its legs and hold it in a tilted position to install the remaining two legs with hex bolts and washers.

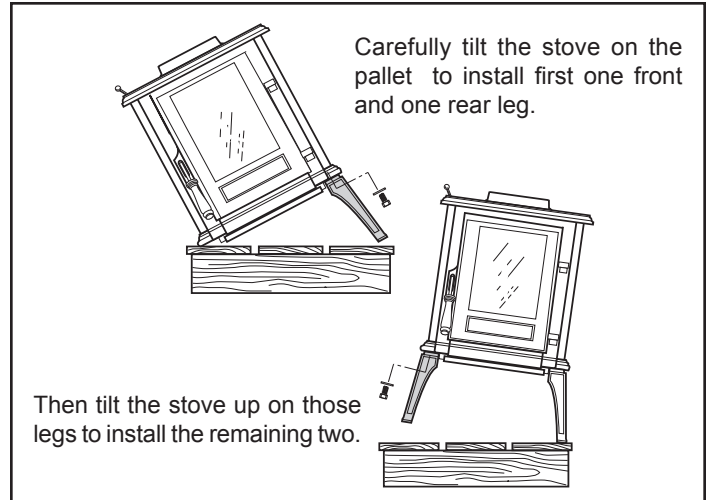

Figure 7.1 - Install legs on one side of stove then the other.

8 Operating Instructions



CAUTION

Approved for use with wood fuel only. The use of any other fuel will void the product warranty and may cause damage to the appliance and/or your home.



WARNING

"NEVER USE GASOLINE, GASOLINE-TYPE LANTERN FUEL, KEROSENE, CHARCOAL LIGHTER FLUID, OR SIMILAR LIQUIDS TO START OR "FRESHEN UP " A FIRE IN THIS HEATER. KEEP ALL SUCH LIQUIDS WELL AWAY FROM THE HEATER WHILE IN USE".

A. Fuel Specifications

Select only **dry, seasoned wood**. Wood for burning should never be exposed to rain or extremely damp conditions. Hardwoods are favored because they are heavier and contain more heating capacity (BTU's) per load than do softwoods. Fuel wood should be split and stored under cover for "seasoning" - at least a year is recommended. Your stove is not an incinerator - do not burn garbage, painted or treated wood, plastic, or other debris.

Keep the area around the stove free from clutter. Keep all combustibles, including fuel, beyond the code-required clearance distance (48" or 1215mm in the U.S., 1525mm or 60" in Canada). Never store fuel in front of the stove where it could interfere with door operation, safe loading, and ash removal.



WARNING

BURNING COLORED PAPER, CARDBOARD, SOLVENTS, TRASH AND GARBAGE OR ALTERING THE STOVE FOR HIGHER HEAT OUTPUT MAY CAUSE DAMAGE TO THE STOVE AND COULD RESULT IN A HOUSE FIRE. USE ONLY APPROVED FUELS AND FOLLOW ONLY THESE OPERATION GUIDELINES.



CAUTION

ALWAYS WEAR FIRE RETARDANT GLOVES WHEN OPERATING THE STOVE.

SAFETY NOTICE

IF THIS APPLIANCE IS NOT PROPERLY INSTALLED, OPERATED AND MAINTAINED, A HOUSE FIRE MAY RESULT. FOR YOUR SAFETY, FOLLOW INSTALLATION DIRECTIONS. CONTACT LOCAL BUILDING OR FIRE OFFICIALS ABOUT RESTRICTIONS AND INSTALLATION INSPECTION REQUIREMENTS IN YOUR AREA.

B. General Information

Before you install and operate your Aspen C3 wood stove, please read the entire contents of this manual. Pay particular attention to the explanation of draft and its effect on stove performance in the Installation section. By following the installation and operating guidelines, you will ensure proper draft and gain maximum efficiency and enjoyment from your stove.

Building a fire too close to the glass may cause damage to the glass, creating a serious risk of fire and property damage.



WARNING

DO NOT BURN GARBAGE OR FLAMMABLE LIQUIDS SUCH AS GASOLINE, NAPHTHA, OR ENGINE OIL.

NOTICE

Due to ash buildup, it is strongly recommended to have your stove professionally cleaned and serviced annually. This includes all parts of the stove, and the venting system.

Installation and repair of this stove should be done by a qualified service person. We recommend that the stove be inspected before use and at least annually by a qualified service person. Periodic cleaning is required throughout the heating season and at the end of each winter for the stove to work efficiently.

Safety Tips:

Conveniently locate a "Class A" fire extinguisher to contend with small fires. Be sure the fire extinguisher works and is clearly visible. All occupants of the house should know where it is, and how it operates. Have heavy stove gloves available near the stove. Have special safety accessories (e.g., Child Guard Screen) available for use if small children will be in the home.

In the event of a stove pipe or chimney fire....

- Evacuate the house immediately
- Notify the fire department
- If the fire isn't too threatening, closing down the stove tight, (primary air, all doors) will help to smother the fire.
- Inspect your stove, stove pipe and chimney for any damage caused by the fire and correct any damage before using your stove again.

DO NOT USE CHEMICALS OR FLUIDS TO START THE FIRE. DO NOT BURN GARBAGE OR FLAMMABLE FLUIDS SUCH AS GASOLINE, NAPTHA, OR ENGINE OIL. Also, never use gasoline-type lantern fuel, kerosene, charcoal lighter fluid, or similar liquids to start or "freshen up" a fire. Keep all such liquids well away from the Aspen C3 while it is in use.

Caution: the Aspen C3 will be hot while in operation. Keep children, clothing and furniture away. Contact may cause skin burns.

DO NOT OVERFIRE THIS HEATER. Overfiring may cause a house fire, or can result in permanent damage to the stove. If any part of the stove glows, you are overfiring.



WARNING

This wood heater has a manufactured-set minimum low burn rate that must not be altered. It is against federal regulations to alter this setting or otherwise operate this wood heater in a manner inconsistent with operating instructions in this manual.

C. Draft Management:

Your stove is only one part of a system that includes the chimney, the operator, the fuel and the home. The other parts of the system will affect how well the stove works. When there is a good match between all the parts, the stove works well.

Wood stove operation depends on natural (unforced) draft. Natural draft occurs when exhaust gas is hotter (and therefore lighter) than the outdoor air at the top of the chimney. The greater the temperature difference, the stronger the draft. As the hot exhaust gas rises out of the chimney it generates suction that draws air into the stove for combustion. A slow, lazy fire indicates a weak draft. A brisk fire, supported only by air entering the stove through the normal inlets, indicates a good draft. The inlets are passive; they regulate how much air can enter the stove, but they do not move air into it.

The efficiency of a modern woodburning appliance, (in which the amount of air available for combustion is regulated), depends on the chimney to keep exhaust gases warm all the way outdoors. The characteristics of your chimney - whether it is steel or masonry, interior or exterior, matched or mismatched to the stove collar - determine how quickly it will warm up and how well it will sustain the optimum temperatures necessary to maintain strong draft and efficient combustion. Here follows a description of various flue system characteristics and related effects on stove performance.

Masonry Chimney:

Although masonry is the traditional material used for chimney construction, it can have distinct performance disadvantages when used to vent a controlled-combustion woodstove. Masonry forms an effective 'heat sink' - that is, it absorbs and holds heat for long periods of time. The large mass, however, may take a long time to become hot enough to sustain a strong draft. The larger the chimney (in total mass), the longer it will take to warm up. Cold masonry will actually cool exhaust gases enough to diminish draft strength. This problem is compounded if the chimney is located outside the home or if the chimney flue has a cross-sectional size larger than the stove outlet.

Steel Chimney:

Most factory-made 'Class A' steel chimneys have a layer of insulation around the inner flue. This insulation keeps the smoke warm and protects the surrounding structure from the high flue temperatures. Because the insulation is less dense than masonry, the inner steel liner warms up more quickly than a masonry chimney. Although steel chimneys are not as attractive as their masonry counterparts, they are very durable and generally outperform masonry.

Inside/Outside Location:

Because the chimney's function is to keep the smoke warm, it is best to locate it inside the house. This location uses the house as insulation for the flue and allows some radiant heat release from the flue into the home. Since an interior chimney does not continuously lose its heat to the outdoors, it takes less heat from the stove to get it warm and keep it warm.

Flue Sizing:

The flue size for a controlled-combustion appliance should be based on the cross-sectional volume of the stove flue outlet. In this case, more is definitely not better. Hot gases lose heat through expansion; if a stove with a six-inch flue collar (28 square inch area) is vented into a 10" x 10" flue, the gases will expand to over three times their original volume. As gases cool with expansion, draft strength decreases. If an oversized flue is also outside the house, the heat it absorbs will be conducted to the outdoor air and the flue will remain relatively cool.

It is common for a masonry flue to be oversized for the stove. Such a chimney can take quite a while to warm up and the stove performance will likely be disappointing. The best solution to an oversize flue problem is the installation of an insulated steel chimney liner of the same diameter as the appliance flue outlet. The liner keeps the exhaust gas warm and the result is a stronger draft. An uninsulated liner is a second choice - although the liner will keep the exhaust restricted to its original volume, the air around the liner will require time and heat energy to warm up.

Check your local codes. You may be required to install a flue liner in any oversize or masonry flue.

Pipe & Chimney Layout:

Every bend in the flue will act as a brake on the exhaust as it flows from the firebox to the chimney cap. The ideal pipe and chimney layout is straight up from the stove through a completely straight chimney. Use this layout if at all possible as it will promote optimum stove performance and simplify maintenance.

If the stovepipe must elbow to enter a chimney, locate the elbow about midway between the stove top and the chimney thimble. This configuration lets the smoke speed up before it must turn, keeps some pipe in the room for heat transfer, and allows long-term flexibility for installing a different appliance without relocating the thimble.

There should be no more than eight feet of single-wall stove pipe between the stove and a chimney. Longer runs can cool the smoke enough to cause draft and creosote problems. Use double-wall stove pipe for longer runs.

Single Venting:

Your stove requires a dedicated flue. Do not connect the stove to a flue used by any other appliance. Chimney draft is a natural form of energy and follows the path of least resistance. If the stove is vented to a flue that also serves an open fireplace or another appliance, the draft will also pull air in through those avenues. The additional air flow will lower flue temperatures, reduce draft strength and promote creosote development; overall stove performance will suffer. The effect is similar to that of a vacuum cleaner with a hole in the hose. In some extreme instances, the other appliance can even impose a negative draft and result in a dangerous draft reversal.

Fuel:

Even the best stove installation will not perform well if poor fuel is used. If available, always use hardwood that has been air-dried ('seasoned') 12-18 months. Softwood burns more rapidly than hardwood and has a high resin content conducive to creosote production. Decayed wood of any type has little heat value and should not be used.

All unseasoned ('green') wood has a high moisture content. Much of its heat value will be used to evaporate moisture before the wood can burn. This significantly reduces not only the amount of energy available to warm your home, but also the intensity of the fire and temperature of the exhaust gas. Incomplete combustion and cool flue temperatures promote creosote formation and weak draft.

You can judge the moisture content of wood by its appearance and weight or use a commercially available moisture meter for an exact measurement. Unseasoned wood will be a third heavier than dry wood. Also, look for cracks ('checking') in the ends of the log that result from contraction as the wood dries. The longer and wider the cracks, the dryer the wood is. Purchase your fuel from a reputable dealer.

Creosote:

Creosote is a by-product of low-temperature stove operations, weak draft or both. It is a tar that results when unburned gases condense inside the flue system at temperatures below 290°F. Creosote is volatile and can generate chimney fire. All of the installation characteristics that adversely affect chimney draft also promote creosote condensation. Consequently, you can minimize creosote accumulation with an effective chimney design and the use of operational techniques that encourage good draft and complete combustion.

Backpuffing:

Backpuffing is a condition that results when the draft is too weak to pull flue gases out of the chimney system as fast as the fire is generating more. Volatile gases build up within the firebox until reaching a density and temperature at which they ignite. With this ignition, you may hear a muffled popping sound and see a bit of smoke forced out of the air inlets.

This condition is most likely to occur in the spring or fall when moderate outdoor temperatures and low intensity fires combine to inhibit draft strength. Avoid large loads of firewood at one time. You should always see lively, dancing flames in the firebox; a lazy, smoky fire is inefficient and will promote draft problems.

Negative Pressure:

Good draft also depends on a sufficient supply of air to the stove. The chimney cannot pull more air than is available. Sluggish draft can be caused by a house that is tight enough to prevent the ready flow of air to the stove, or by competition between the stove and other appliances that vent indoor air to the outside; i.e., exhaust fans for range hoods, clothes dryers, bathroom, etc. If the chimney draws well when all such equipment is turned off (or sealed, in the case of the fireplaces and/or other stoves), you simply need to be attentive in timing the use of the other appliances. If you need to crack a nearby window or door to enable the chimney to pull well, install outside air to bring combustion air directly to the stove.

Conclusion:

Woodburning is more an art than a science. Over time, you will become familiar with the intricacies and nuances of your particular installation and you will be able to identify cause and effect in a variety of seasonal circumstances.

D. Combustion Process

How the Aspen C3 Works:

Combustion control is achieved in the Aspen C3 through two separate air delivery systems.

The Aspen C3 features an automatic thermostat to ensure an even heat output. As the fuel burns, the thermostat reacts to the heat radiating from the stove surface and, consequently, adjusts the air shutter attached to it. As the fire intensity (and heat output) builds, the thermostat slowly closes the air shutter, thereby restricting incoming combustion air. As the fire intensity then wanes (and heat output lessens), the thermostat responds and gradually opens the air shutter which allows more combustion air to again enliven the fire. This ebb and flow action functions continuously to prolong the burn cycle until the fuel bed is exhausted.

Another separate supply of oxygen is delivered to the upper area of the firebox to support combustion of gases released from the main fuel bed. This **Secondary Air** enters the stove and is heated while passing through separate channels before being delivered at the top of the firebox.

Burn Only High-Quality Wood

THE ASPEN C3 IS DESIGNED TO BURN NATURAL WOOD ONLY; DO NOT BURN ANY OTHER FUELS.

You will enjoy the best results when burning wood that has been adequately air-dried. Avoid burning "green" wood that has not been properly seasoned. The wood should be no longer than 18" (410 mm) in length, however, you will find that thinner cuts ease refueling and promote the most efficient combustion.

The best hardwood fuels include oak, maple, beech, ash, and hickory that has been split, stacked, and air-dried outside under cover for at least one year.

For areas that do not have a supply of hardwood, commonly burned softwoods include tamarack, yellow pine, white pine, Eastern red cedar, fir, and redwood. These too should be properly dried.

Keep wood a safe distance from the heater and keep it out of the areas around the heater used for refueling and ash removal.

E. Building and Maintaining a Fire



WARNING

OPERATE THIS STOVE ONLY WITH THE DOOR FULLY CLOSED.

BURN SOLID WOOD FUEL ONLY, AND BURN IT DIRECTLY ON THE GRATE. DO NOT ELEVATE THE FUEL. DO NOT BURN COAL OR OTHER FUELS.

Cast iron is extremely strong, but it can be broken with a sharp blow from a hammer or from the thermal shock of rapid and extreme temperature change.

The cast plates expand and contract with changes in temperature. When you first begin using your Aspen C3, minimize thermal stress by allowing the plates to adjust gradually during three or four initial break-in fires following Steps.

1. Place several sheets of crumpled newspaper in the stove. Avoid using glossy or colored paper, as these burn poorly. At the front of the firebox, place on the paper six or eight pieces of dry kindling split to a finger-width size, and on the kindling lay two or three larger sticks of split dry wood approximately 1-2" (25-51 mm) in diameter.
2. Light the newspaper and close the door. Gradually build up the fire by adding a few 3-5" (80-120 mm) diameter splits. **If this is one of the first few "break-in" fires, let the fire burn brightly, and then let it die out.**
 - Some odor from the stove's hot metal, the paint, and the cement is normal for the first few fires.

NOTE: Some chimneys need to be "primed," or warmed up, before they will draw sufficiently to sustain a fire. To correct this situation, roll up a couple pieces of newspaper, place them on top of the kindling and toward the back of the stove, light them, and close the door. This should heat the chimney enough to initiate strong draft.

Once the draft is established, open the front door and light the rest of the fuel bed at the bottom. Do not light the main bed of fuel until the chimney begins drawing.

NOTE: Effectiveness of a "top-down" method to start a fire. Smoke emissions when starting a fire can be difficult to control because the stove is not yet heated to its optimum temperature. One method of reducing emissions during a cold start-up is the use of a "top-down" kindling procedure. In this, place larger pieces of kindling on the bottom of the kindling pile followed by smaller and smaller pieces as the pile is added to. Very finely split pieces should be on the top.

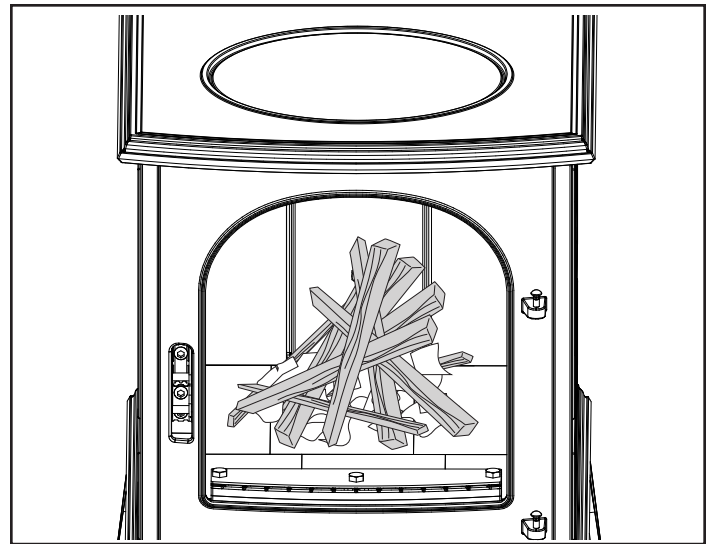

Figure 8.1 - Start a fire with small, dry kindling.

Light the kindling pile with a match at the top and allow the kindling to burn downward into the larger pieces. This reduces smoke by slowly increasing the fire size without creating an air-starved condition.

3. **After the stove has been broken-in** using Steps 1-2, continue to build the fire gradually. Add larger wood with a diameter of 3-4" (75-102 mm).

Refuel While the Embers Are Still Hot:

Reload the Aspen C3 while it is still hot and there are plenty of glowing embers to re-kindle the fire. Include some smaller pieces of wood in the new load of fuel to help the stove return to its operating temperature quickly. Wear stove gloves, and follow this procedure when you reload your stove:

1. Use a fireplace tool to break up the charcoal. Pull the charcoal from the back to the front. This will encourage efficient combustion as the fuel burns from front to rear. Take care, however, not to block the primary air box with coals or ash, Figure 8.2.
2. Load wood - smaller, split pieces first. Close the door.

Ash Disposal:

Remove ash before it reaches the top of the Primary Air Box, Figure 8.2. Check the level at least once a day, and before each re-fueling.

Dispose of ashes into a metal container with a tight-fitting lid kept outdoors. Put the closed container of ash on a noncombustible floor or on the ground, well away from all combustible materials, pending final disposal. If the ash is disposed of by burial in soil or otherwise locally dispersed, keep it in the closed container until all cinders have thoroughly cooled. You can use wood ash as a garden fertilizer.

Empty the ashes regularly, typically every one to three days. The frequency will vary depending on how you operate your Aspen C3.



CAUTION

Never use your household or shop vacuum cleaner to remove ash from the stove; always remove and dispose of the ash properly.

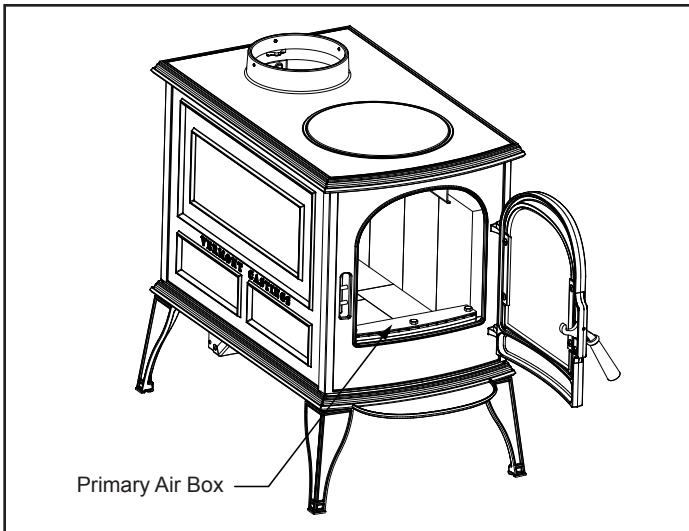

Figure 8.2

9 Service & Maintenance

Solid fuel burning space heaters must be cleaned regularly, as soot, ash and creosote may accumulate.

When properly maintained, your wood stove will give you many years of trouble-free service. **Contact your dealer** to answer questions regarding proper operation, trouble-shooting and service for your appliance. Visit www.vermontcastings.com to find a dealer. We recommend annual service by a qualified service technician.

Let the fire in the stove go out and allow the stove to cool completely before beginning any maintenance procedure.

A. Care of the Cast Iron Surface

An occasional dusting with a dry rag will keep the painted cast iron of your Aspen C3 looking new.

The stove's paint can be touched up as needed. First, clean the areas to be painted with a wire brush. Then, touch up the stove with high temperature stove paint. Apply the paint sparingly, and keep in mind that two light coats of paint are better than a single heavy one.

B. Front Door Maintenance

Cleaning the Glass:

Most of the carbon deposits on the glass will burn off during hot fires. However, the ash residue that accumulates on the glass surface should be removed regularly to prevent etching. Follow this procedure to clean the glass:

- Be sure the glass is completely cool.
- Clean the glass with water or a cleaner made especially for this purpose. Do not use abrasive cleaners.
- Rinse the glass thoroughly.
- Dry the glass completely.

Glass Replacement:

Replace glass only with Vermont Castings part no. 3-40-950144. The glass panel rests on a cushion provided by gasket, and is held in place by (4) clips, Figure 9.1. Remove the door from the stove and place it on a sturdy, level work surface. Use a towel to protect the finish.

1. Remove the (4) Retainer Clips. (one phillips head screw on each clip).
2. Replace the gasket as shown in Figure 9.1.
3. To install the glass, lay it on the door with the gasket side down and tighten clips.

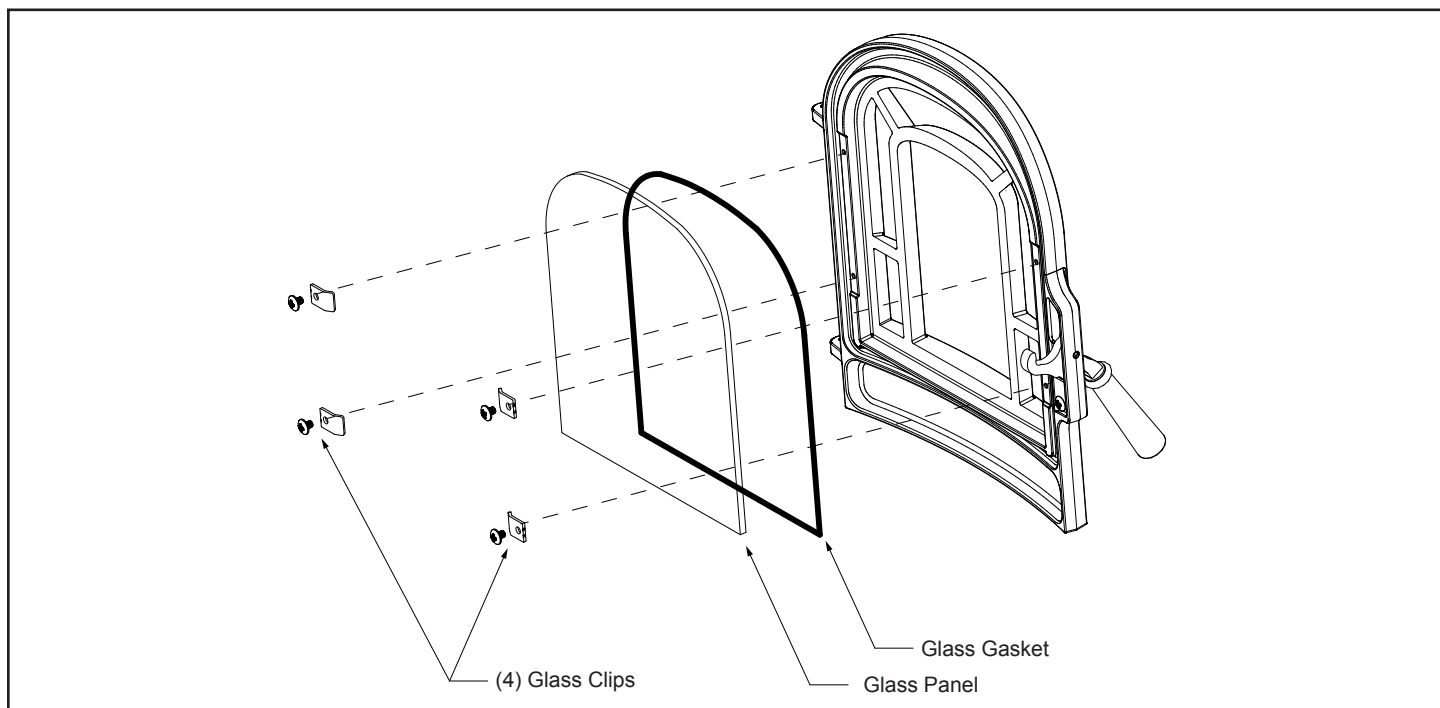

Figure 9.1 - Door glass installation.

Gasket Replacement:

Your Aspen C3 uses rope-type fiberglass gaskets to make a tight seal between some parts. With use, particularly on those parts that move, gaskets can become brittle and compressed and can begin to lose their effectiveness. These will need periodic replacement.

The sizes of replaceable gasket are listed below, along with their applications.

<u>Gasket Diameter...</u>	<u>...And the Parts it Seals</u>
---------------------------	----------------------------------

3/8" Round	Door Gasket
3/16" Round w/PSA	Gasket for glass

Wait until the fire is out and the stove has cooled. Be sure to follow the standard safety procedure for working with dusty materials: Wear safety goggles and a dust mask.

1. Remove the existing gasket by grasping an end and pulling firmly.
2. Use a wire brush or a screwdriver to clean the channel of any remaining cement or bits of gasket. Remove stubborn deposits of cement with a cold chisel if necessary.
3. Determine the correct length of the appropriate-sized gasket by laying it out in the channel. Allow an extra 1-2" (25-51 mm), and mark the spot to be cut.
4. Remove the gasket from the channel, place it on a wood cutting surface, and cut it at the marked spot with a utility knife. Twist the ends slightly to discourage the gasket from unraveling.
5. Lay an unbroken 1/8" (3 mm) bead of gasket cement in the newly-cleaned channel.
6. Starting at one end, press the gasket into the channel. Ensure a good joint where the gasket meets before trimming any excess. Do not overlap the gasket ends or leave ends with ragged edges.
7. Press the gasketed part firmly against its normal mating surface to seat the gasket evenly in its channel. Close and latch the door to do this; close the door on a piece of waxed paper to keep the cement from migrating onto the non-gasketed part, or tap other parts
8. Clean excess cement from around the channel. Let the cement that holds the new gasket dry thoroughly.

Adjust the Door:

The door latch may need adjusted as the gasket material compresses over time. The latch may be tightened using the following steps:

1. Slightly loosen the 1/4-20 Hex bolt located at the rear of the latch assembly inside the firebox, Figure 9.1.
2. Tighten the top 1/4-20 Button Head screw, Figure 9.2.

Adjust as needed until a snug fit is achieved.

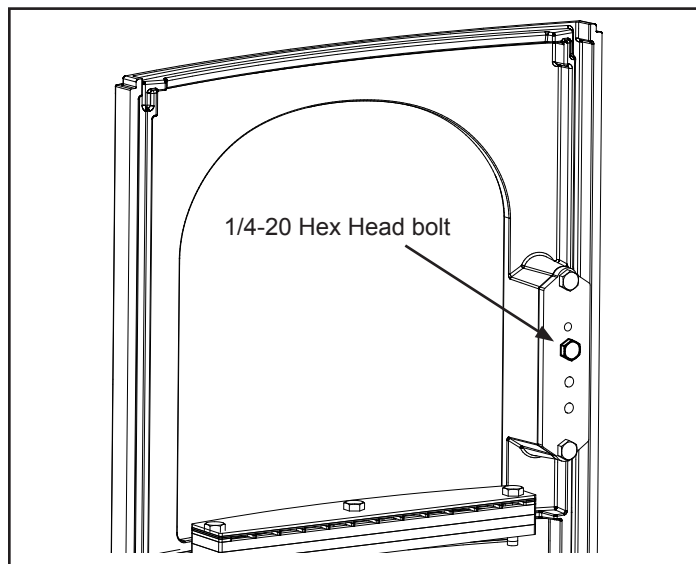

Figure 9.1 - Loosen 1/4-20 Hex head Bolt

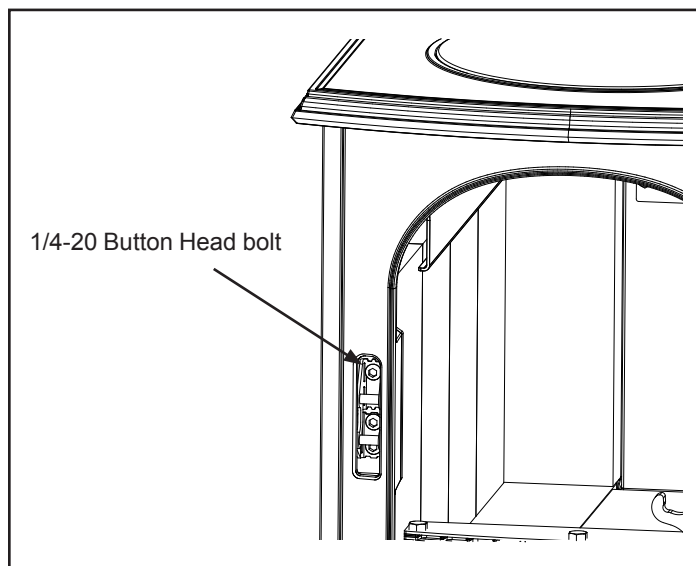

Figure 9.2 - Tighten 1/4-20 Button head Bolt

C. The Chimney System

Creosote:

Your Aspen C3 is designed to reduce creosote buildup significantly. However, regular chimney inspection and maintenance must still be performed. For safety, good stove performance, and to protect your chimney and chimney connector, inspect your chimney and chimney connector on a regular schedule. Clean the system if necessary. Failure to keep the chimney and connector system clean can result in a serious chimney fire.

When wood is burned slowly, it produces tar, organic vapors and moisture that combine to form creosote. The creosote vapors condense in the relatively cool chimney flue. As a result, creosote residue accumulates on the flue lining. When ignited, this creosote makes an extremely hot fire within the flue system that can damage the chimney and overheat adjacent combustible material.

If you do have a chimney fire, promptly:

- **Get everyone out of the house.**
- **Call the Fire Department.**

You should inspect the system every two weeks during the heating season as part of a regular maintenance schedule. To inspect the chimney, let the stove cool completely. Then, using a mirror and a strong light, sight up through the flue collar into the chimney flue. If it is not possible to inspect the flue system in this fashion, the stove must be disconnected to provide better viewing access.

If a significant layer of creosote has accumulated - 1/8" (3 mm) or more - remove it to reduce the risk of a chimney fire.

Clean the chimney using a brush the same size and shape as the flue liner. Flexible fiberglass rods are used to run the brush up and down the liner, causing any deposits to fall to the bottom of the chimney where they can be removed through the clean-out door.

The chimney connector should be cleaned by disconnecting the sections, taking them outside, and removing any deposits with a stiff wire brush. Reinstall the connector sections after cleaning, being sure to secure the individual sections with sheet metal screws.

If you cannot inspect or clean the chimney yourself, contact your local Vermont Castings' Authorized Dealer or hire a professional chimney sweep.

Annual Maintenance:

Perform a thorough cleaning, inspection and repair each Spring, at the end of the heating season.

- Thoroughly clean the chimney and chimney connector.
- Inspect the chimney for damage and deterioration. Replace weak sections of prefabricated chimney. Have a mason make repairs to a masonry chimney.
- Inspect the chimney connector and replace any damaged sections.

- Check gasketing for wear or compression, and replace if necessary. A 'paper test' will guide you on this. Close and lock the door on a slip of paper and then try to pull the paper out. If the paper pulls out with little or no resistance, the gasket isn't snug enough at that spot. If adjusting the latch doesn't result in a seal that makes it hard to pull the paper out, replace the gasketing.
- Check door handle for tightness. Adjust if needed.
- Remove ashes from the firebox and install moisture absorbing material (such as cat litter) to keep the stove interior dry.
- Touch up the paint on black stoves.

D. Service Parts List

Beginning Manufacturing Date: N/A
Ending Manufacturing Date: Active

0001920 (Classic Black)

0001923 (Bordeaux) (End Manufacturing Date: 2017)

0001924 (Ebony) (Ending Manufacturing Date: 2007)

0001927 (Majolica Brown) (Ending Manufacturing Date: 2008)

0001928 (Vermont Classic Green) (Ending Manufacturing Date: 2008)

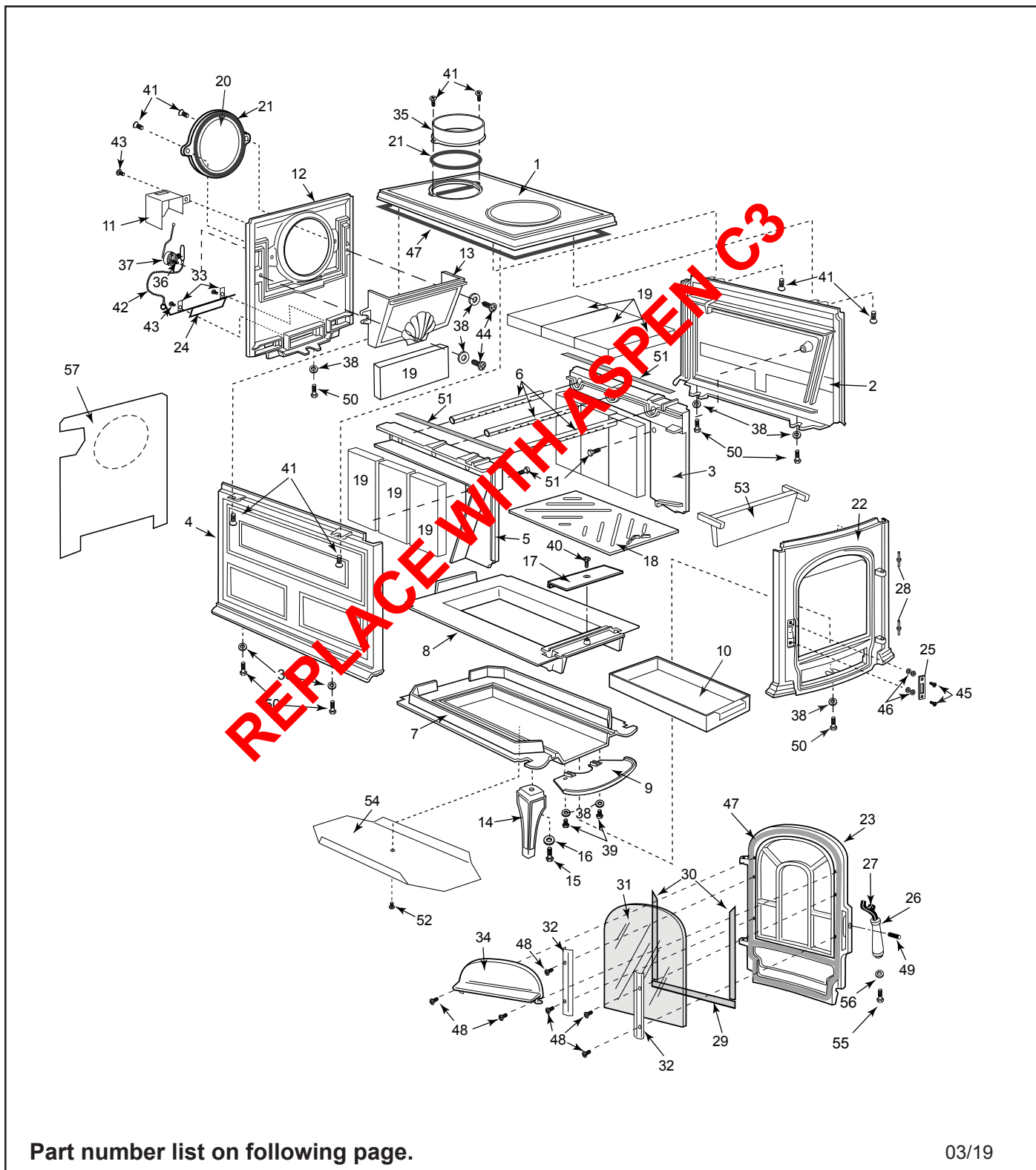

Part number list on following page.

03/19

Beginning Manufacturing Date: N/A
Ending Manufacturing Date: Active

IMPORTANT: THIS IS DATED INFORMATION. Parts must be ordered from a dealer or distributor. **Hearth and Home Technologies does not sell directly to consumers.** Provide model number and serial number when requesting service parts from your dealer or distributor.



Stocked
at Depot

ITEM	DESCRIPTION	COMMENTS	PART NUMBER	
1	Top	Classic Black	30001654A	
		Bordeaux	30006803	
2	Right Side	Classic Black	30001655A	
		Bordeaux	30006805	
3	Secondary Air Channel, Right		30000606	
4	Left Side	Classic Black	30001656A	
		Bordeaux	30006806	
5	Secondary Air Channel, Left		30000607	
6	Secondary Air Tube		30000368	
7	Bottom		30000343A	
8	Bottom, Inner		30000346	
9	Ashlip	Classic Black	30000352A	
		Bordeaux	30006808	
10	Ashpan		30000363	
11	Thermostat		30000371	
12	Back		30000347A	
13	Fire Back		30000358	
14	Leg (Qty. 4 req)	Classic Black	30000360A	
		Bordeaux	30006807	
	Leg (Set of 4)	Classic Black	K30000502	
		No longer available	30006810	
15	Leg Bolt, 3/8-16x1, Hex Bolt	Qty 4 req	1201432	
16	Flat Washer, 3/8	Pkg of 10	1202488-10	
17	Primary Air Plate		30000356	
18	Grate, Wood		30000604A	
19	Firebrick	Qty 10 req	1601103	Y
20	Flue Cover	Classic Black	30000351A	
		Bordeaux	30006800	
21	Adhesive Gasket, 5/16	15 Ft	1-00-1203591	Y
22	Front	Classic Black	30000348A	
		Bordeaux	30006801	
23	Door	Classic Black	30000350A	
		Bordeaux	30006802	
24	Primary Air Flap		30000370A	
25	Door Handle Catch		30000365	
26	Wooden Handle		30000366	
27	Door Handle Shaft		30000364	

Additional service part numbers appear on following page.

Beginning Manufacturing Date: N/A
Ending Manufacturing Date: Active

IMPORTANT: THIS IS DATED INFORMATION. Parts must be ordered from a dealer or distributor. **Hearth and Home Technologies does not sell directly to consumers.** Provide model number and serial number when requesting service parts from your dealer or distributor.



Stocked at Depot

ITEM	DESCRIPTION	COMMENTS	PART NUMBER	
28	Door Pin, Long		1600416	
29	Glass Gasket, Horizontal 8-1/4		30000382	
30	Glass Gasket, Vertical	Qty 2 req	30000383	
31	Glass Panel		30000362	
32	Glass Retainer	Qty 2 req	30000474	
33	Clip	Qty 2 req	1601394	Y
34	Door Manifold		30000357	
35	Flue Collar	Classic Black	30000353A	
		Bordeaux	30006804	
36	Friction Spring	Pkg of 10	1201846-10	
37	Primary Thermostat Assembly		30000503	Y
38	Flat Washer, Zinc 1/4	Pkg of 10	1202474-10	
39	Hex Screw, 1/4-20x5/8	Pkg of 10	1201372-10	
40	Flat Head Phillips Screw, 1/4-20x1-1/4	Pkg of 10	1200811-10	
41	Flat Head Phillips Screw, 1/4-20x3/4	Pkg of 10	1200881-10	
42	Ball Chain, Thermostat		1201960	
43	Plain Truss Head Screw, 10-20x1/4	Pkg of 10	1200996-10	
44	Round Head Phillips Screw, 1/4-20x5/8	Pkg of 10	1200896-10	
45	Round Head Phillips Screw, 1/4-20x3/8		1200894	
46	Flat Washer, 1/4	Pkg of 25	3-30-0305-25	
47	Round Gasket, 7/16	15 Ft	1-00-7000910	Y
48	Round Head Slotted Screw, 10-24x3/8	Pkg of 10	1200983-10	
49	Roll Pin, 3/16x1		1201833	
50	Hex Head Screw, 1/4-20x1	Pkg of 10	1201376-10	
51	Gasket, Flat with Adhesive	10 Ft	1-00-30000504	Y
52	Hex Head Phillips Screw, 1/4-20x3/8	Pkg of 10	1201053-10	
53	Deflector Rib		30000597	
54	Bottom Heat Shield		30000384	
55	Handle, Screw Pan Head Phillips		1200986	Y
56	Washer, Flat #10 .218 id x .5 od		1202423	
57	Rear Heat Shield		0001896	
	Spacer HS 1 25 NI	Pkg of 10	1601755-10	
	Touch Up Paint	Classic Black	3-42-19905	
		Bordeaux	0001341	

E. Warranty

Hearth & Home Technologies LIMITED LIFETIME WARRANTY

Hearth & Home Technologies, on behalf of its hearth brands (“HHT”), extends the following warranty for HHT gas, wood, pellet and electric hearth appliances that are purchased from an HHT authorized dealer.

WARRANTY COVERAGE:

HHT warrants to the original owner of the HHT appliance at the site of installation, and to any transferee taking ownership of the appliance at the site of installation within two years following the date of original purchase, that the HHT appliance will be free from defects in materials and workmanship at the time of manufacture. After installation, if covered components manufactured by HHT are found to be defective in materials or workmanship during the applicable warranty period, HHT will, at its option, repair or replace the covered components. HHT, at its own discretion, may fully discharge all of its obligations under such warranties by replacing the product itself or refunding the verified purchase price of the product itself. The maximum amount recoverable under this warranty is limited to the purchase price of the product. This warranty is subject to conditions, exclusions and limitations as described below.

WARRANTY PERIOD:

Warranty coverage for consumers begins at the date of installation. In the case of new home construction, warranty coverage begins on the date of first occupancy of the dwelling or six months after the sale of the product by an independent, authorized HHT dealer/distributor, whichever occurs earlier. However, the warranty shall commence no later than 24 months following the date of product shipment from HHT, regardless of the installation or occupancy date. The warranty period for parts and labor for covered components is produced in the following table.

The term “Limited Lifetime” in the table below is defined as: 20 years from the beginning date of warranty coverage for gas appliances, and 10 years from the beginning date of warranty coverage for wood and pellet appliances. These time periods reflect the minimum expected useful lives of the designated components under normal operating conditions.

Warranty Period		HHT Manufactured Appliances and Venting					
Parts	Labor	Gas	Pellet	Wood	Electric	Venting	Components Covered
1 Year		X	X	X	X	x	All parts and material except as covered by Conditions, Exclusions, and Limitations listed
2 years			X	X			Igniters, auger motors, electronic components, and glass
		X	X	X			Factory-installed blowers
				X			Molded refractory panels
		X					Ignition Modules
3 years			X				Firepots, burnpots, mechanical feeders/auger assemblies
5 years	1 year	X					Vent Free burners, Vent Free ceramic fiber logs, Aluminized Burners
			X	X			Castings and Baffles
6 years	3 years			X			Catalyst - limitations listed
7 years	3 years		X	X			Manifold tubes, HHT chimney and termination
10 years	1 year	X					Burners, logs and refractory
Limited Lifetime	3 years	X	X	X			Firebox and heat exchanger, Grate and Stainless Steel Burners, FlexBurn® System (engine, inner cover, access cover and fireback)
90 Days		X	X	X	X	X	All replacement parts beyond warranty period

WARRANTY CONDITIONS:

- This warranty only covers HHT appliances that are purchased through an HHT authorized dealer or distributor. A list of HHT authorized dealers is available on the HHT branded websites.
- This warranty is only valid while the HHT appliance remains at the site of original installation.
- This warranty is only valid in the country in which the HHT authorized dealer or distributor that sold the appliance resides.
- Contact your installing dealer for warranty service. If the installing dealer or distributor is unable to provide necessary parts, contact the nearest HHT authorized dealer or supplier. Additional service fees may apply if you are seeking warranty service from a dealer other than the dealer from whom you originally purchased the product.
- Check with your dealer in advance for any costs to you when arranging a warranty call. Travel and shipping charges for parts are not covered by this warranty.
- Limited Catalyst Warranty
 - o For wood burning products containing a catalyst, the catalyst will be warranted for a six-year period as follows: if the original catalyst or a replacement catalyst proves defective or ceases to maintain 70% of its particulate emission reduction activity (as measured by an approved testing procedure) within 36 months from the purchase date, the catalyst will be replaced for free.
 - o From 37 to 72 months a pro-rated credit will be allowed against a replacement catalyst and labor credit necessary to install the replacement catalyst. The proration rate is as follows:

Amount of Time Since Purchase	Credit Towards Replacement Cost
0 - 36 Months	100%
37 - 48 Months	30%
49 - 60 Months	20%
61 - 72 Months	10%

- o Any replacement catalyst will be warranted under the terms of the catalyst warranty for the remaining term of the original warranty. The purchaser must provide the name, address, and telephone number of the location where the product is installed, proof of original purchase date, date of failure, and any relevant information regarding the failure of the catalyst.

WARRANTY EXCLUSIONS:

This warranty does not cover the following:

- Changes in surface finishes as a result of normal use. As a heating appliance, some changes in color of interior and exterior surface finishes may occur. This is not a flaw and is not covered under warranty.
- Damage to printed, plated, or enameled surfaces caused by fingerprints, accidents, misuse, scratches, melted items, or other external sources and residues left on the plated surfaces from the use of abrasive cleaners or polishes.
- Repair or replacement of parts that are subject to normal wear and tear during the warranty period are not covered. These parts include: paint, wood and pellet gaskets, firebricks, grates, flame guides, batteries and the discoloration of glass.
- Minor expansion, contraction, or movement of certain parts causing noise. These conditions are normal and complaints related to this noise are not covered by this warranty.
- Damages resulting from: (1) failure to install, operate, or maintain the appliance in accordance with the installation instructions, operating instructions, and listing agent identification label furnished with the appliance; (2) failure to install the appliance in accordance with local building codes; (3) shipping or improper handling; (4) improper operation, abuse, misuse, continued operation with damaged, corroded or failed components, accident, or improperly/incorrectly performed repairs (5) environmental conditions, inadequate ventilation, negative pressure, or drafting caused by tightly sealed constructions, insufficient make-up air supply, or handling devices such as exhaust fans or forced air furnaces or other such causes; (6) use of fuels other than those specified in the operation instructions; (7) installation or use of components not supplied with the appliance or any other components not expressly authorized and approved by HHT; (8) modification of the appliance not expressly authorized and approved by HHT in writing; and/or (9) interruptions or fluctuations of electrical power supply to the appliance.
- Non-HHT venting components, hearth connections or other accessories used in conjunction with the appliance.
- Any part of a pre-existing fireplace system in which an insert or a decorative gas appliance is installed.
- HHT’s obligation under this warranty does not extend to the appliance’s capability to heat the desired space. Information is provided to assist the consumer and the dealer in selecting the proper appliance for the application. Consideration must be given to the appliance location and configuration, environmental conditions, insulation and air tightness of the structure.

This warranty is void if:

- The appliance has been over-fired, operated in atmospheres contaminated by chlorine, fluorine, or other damaging chemicals. Over-firing can be identified by, but not limited to, warped plates or tubes, deformation/warping of interior cast iron structure or components, rust colored cast iron, bubbling, cracking and discoloration of steel or enamel finishes.
- The appliance is subjected to prolonged periods of dampness or condensation.
- There is any damage to the appliance or other components due to water or weather damage which is the result of, but not limited to, improper chimney or venting installation.

LIMITATIONS OF LIABILITY

- The owner's exclusive remedy and HHT's sole obligation under this warranty, under any other warranty, express or implied, or in contract, tort or otherwise, shall be limited to replacement, repair, or refund, as specified above. In no event will HHT be liable for any incidental or consequential damages caused by defects in the appliance. Some states do not allow exclusions or limitation of incidental or consequential damages, so these limitations may not apply to you. This warranty gives you specific rights; you may also have other rights, which vary from state to state. EXCEPT TO THE EXTENT PROVIDED BY LAW, HHT MAKES NO EXPRESS WARRANTIES OTHER THAN THE WARRANTY SPECIFIED HEREIN. THE DURATION OF ANY IMPLIED WARRANTY IS LIMITED TO DURATION OF THE EXPRESSED WARRANTY SPECIFIED ABOVE.



352 Mountain House Road • Halifax, Pa 17032
www.vermontcastings.com